

# **GENESYS™ Series**

## **Programmable DC Power Systems**

**GSPS / GBSPS 30kW in 20U 0–600V / 0–3000A**

**GSPS / GBSPS 45kW in 20U 0–1500V / 0–2250A**

**GSPS / GBSPS 60kW in 20U 0–600V / 0–4500A**

**GSPS / GBSPS 67.5kW in 20U 0–1500V / 0–67.5A**

**GSPS / GBSPS 90kW in 20U 0–1500V / 0–4500A**

**Built-in *LXI* compliant LAN, USB, RS-232, and RS-485 Interface**

**Built-in Remote Isolated Analog Program/Monitor/Control Interface**

**Optional Interface: IS420, IEEE488.2 (GPIB), MODBUS TCP, EtherCAT, or EtherNet/IP**

## **SAFETY AND INSTALLATION MANUAL**

### **Manual Supplements**

The full user manual is available on TDK-Lambda website or can be ordered; refer to user manual IA761-04-02\_.

For units equipped with MODBUS TCP interface option, refer to MODBUS TCP user manual IA761-04-04\_.

For units equipped with EtherCAT interface option, refer to EtherCAT user manual IA761-04-05\_.

For units equipped with EtherNet/IP interface option, refer to EtherNet/IP User manual IA761-04-06\_.

Modbus® is a registered trademark of Schneider Electric, licensed to the Modbus Organization, Inc.

EtherCAT® is a registered trademark and patented technology, licensed by Beckhoff Automation GmbH, Germany.

EtherNet/IP® is a registered trademark of ODVA Inc., managed and licensed by ODVA for use with devices compliant with the Common Industrial Protocol (CIP®).

This page intentionally left blank

# This Manual Covers Models:

## 30kW

<b>GSPS10-3000*</b>	<b>GSPS100-300</b>	<b>GBSPS10-3000*</b>	<b>GBSPS100-300</b>
<b>GSPS20-1500</b>	<b>GSPS150-204</b>	<b>GBSPS20-1500</b>	<b>GBSPS150-204</b>
<b>GSPS30-1020</b>	<b>GSPS200-150</b>	<b>GBSPS30-1020</b>	<b>GBSPS200-150</b>
<b>GSPS40-750</b>	<b>GSPS300-102</b>	<b>GBSPS40-750</b>	<b>GBSPS300-102</b>
<b>GSPS50-600</b>	<b>GSPS400-78</b>	<b>GBSPS50-600</b>	<b>GBSPS400-78</b>
<b>GSPS60-510</b>	<b>GSPS500-60</b>	<b>GBSPS60-510</b>	<b>GBSPS500-60</b>
<b>GSPS80-390</b>	<b>GSPS600-51</b>	<b>GBSPS80-390</b>	<b>GBSPS600-51</b>

## 45kW

<b>GSPS20-2250</b>	<b>GSPS200-225</b>	<b>GBSPS20-2250</b>	<b>GBSPS200-225</b>
<b>GSPS30-1530</b>	<b>GSPS300-153</b>	<b>GBSPS30-1530</b>	<b>GBSPS300-153</b>
<b>GSPS40-1125</b>	<b>GSPS400-117</b>	<b>GBSPS40-1125</b>	<b>GBSPS400-117</b>
<b>GSPS50-900</b>	<b>GSPS500-90</b>	<b>GBSPS50-900</b>	<b>GBSPS500-90</b>
<b>GSPS60-765</b>	<b>GSPS600-76.5</b>	<b>GBSPS60-765</b>	<b>GBSPS600-76.5</b>
<b>GSPS80-585</b>	<b>GSPS1000-45</b>	<b>GBSPS80-585</b>	<b>GBSPS1000-45</b>
<b>GSPS100-450</b>	<b>GSPS1500-30</b>	<b>GBSPS100-450</b>	<b>GBSPS1500-30</b>
<b>GSPS150-306</b>	-	<b>GBSPS150-306</b>	-

## 60kW

<b>GSPS10-4500**</b>	<b>GSPS100-600</b>	<b>GBSPS10-4500**</b>	<b>GBSPS100-600</b>
<b>GSPS20-3000</b>	<b>GSPS150-408</b>	<b>GBSPS20-3000</b>	<b>GBSPS150-408</b>
<b>GSPS30-2040</b>	<b>GSPS200-300</b>	<b>GBSPS30-2040</b>	<b>GBSPS200-300</b>
<b>GSPS40-1500</b>	<b>GSPS300-204</b>	<b>GBSPS40-1500</b>	<b>GBSPS300-204</b>
<b>GSPS50-1200</b>	<b>GSPS400-156</b>	<b>GBSPS50-1200</b>	<b>GBSPS400-156</b>
<b>GSPS60-1020</b>	<b>GSPS500-120</b>	<b>GBSPS60-1020</b>	<b>GBSPS500-120</b>
<b>GSPS80-780</b>	<b>GSPS600-102</b>	<b>GBSPS80-780</b>	<b>GBSPS600-102</b>

\*Refer to the 30kW specifications for details on de-rating.

\*\*Refer to the 60kW specifications for details on de-rating.

**67.5kW**

<b>GSPS1000-67.5</b>	<b>GBSPS1000-67.5</b>
<b>GSPS1500-45</b>	<b>GBSPS1500-45</b>

**90kW**

<b>GSPS20-4500</b>	<b>GSPS200-450</b>	<b>GBSPS20-4500</b>	<b>GBSPS200-450</b>
<b>GSPS30-3000</b>	<b>GSPS300-300</b>	<b>GBSPS30-3000</b>	<b>GBSPS300-300</b>
<b>GSPS40-2256</b>	<b>GSPS400-225</b>	<b>GBSPS40-2256</b>	<b>GBSPS400-225</b>
<b>GSPS60-1500</b>	<b>GSPS600-150</b>	<b>GBSPS60-1500</b>	<b>GBSPS600-150</b>
<b>GSPS80-1128</b>	<b>GSPS1000-90</b>	<b>GBSPS80-1128</b>	<b>GBSPS1000-90</b>
<b>GSPS100-900</b>	<b>GSPS1500-60</b>	<b>GBSPS100-900</b>	<b>GBSPS1500-60</b>
<b>GSPS150-600</b>	<b>-</b>	<b>GBSPS150-600</b>	<b>-</b>

## **Product Test Results**

As part of TDK-Lambda's efforts to protect the global environment and as part of TDK's Sustainability Vision, we are happy to notify you that we have launched an online product test results database.

To reduce paper waste, starting in September 2022, TDK-Lambda Ltd. will stop printing individual product test results which used to be included in a unit's package. Test results will be available online on a dedicated page on our website, starting with all products manufactured as of April 2021.

To view your product's test results, enter the serial number and part number printed on your power system's label on the following webpage:

<https://orders.tdk-lambda.co.il/company-products>

We encourage you to avoid printing test results and instead store a digital copy in your ERP system.

This page intentionally left blank

**TABLE OF CONTENTS**

**GENERAL INFORMATION ..... 1**

**WARRANTY ..... 1**

**ENVIRONMENTAL COMPLIANCE ..... 2**

**INTENDED USE ..... 3**

**LIFTING AND CARRYING ..... 3**

**NORMAL POSITION USE ..... 3**

**INSULATION REQUIREMENTS ..... 3**

**LONG-TERM STORAGE METHOD AND LONG-TERM STORAGE PERIOD..... 4**

**SAFETY AND EMC APPROVALS..... 5**

**GENERAL SAFETY INFORMATION ..... 7**

**CHAPTER 1: GENERAL INFORMATION ..... 13**

    1.1 User Manual Content..... 13

    1.2 Introduction ..... 13

        1.2.1 General Description ..... 13

        1.2.2 Control via Communication Ports..... 13

        1.2.3 Analog Voltage Programming and Monitoring..... 14

        1.2.4 Parallel Operation ..... 14

        1.2.5 Output Connections..... 14

    1.3 Accessories..... 15

        1.3.1 Accessories Provided With the Power System ..... 15

            1.3.1.1 Miscellaneous Hardware ..... 15

            1.3.1.2 Busbars Screws Kits ..... 15

        1.3.2 Optional Accessories..... 16

            1.3.2.1 Serial Link Cables ..... 16

            1.3.2.2 Paralleling Cable ..... 16

            1.3.2.3 Air Filter Option Kit ..... 16

**CHAPTER 2: FRONT/REAR PANEL CONTROLS AND CONNECTORS ..... 17**

    2.1 Introduction ..... 17

    2.2 Master Unit Front Panel Display and Controls..... 17

    2.3 Master Unit Front Panel Display and Indicators ..... 20

    2.4 Master Unit Blank Front Panel Control and Indicators ..... 22

    2.5 Master Unit Rear Panel Connections and Connectors..... 23

    2.6 J1 Connector Terminals and Functions ..... 25

**CHAPTER 3: OUTLINE ..... 27**

**CHAPTER 4: INSTALLATION ..... 32**

    4.1 General..... 32

    4.2 Preparation for Use ..... 32

    4.3 Unpacking and Initial Inspection..... 33

    4.4 Repackaging for Shipment ..... 35

    4.5 Location, Mounting, and Cooling..... 36

    4.6 Preparing the Power System for the Connections..... 36

    4.7 AC Input Power Connection ..... 38

    4.8 Turn-On Check Procedure..... 42

4.8.1	General .....	42
4.8.2	Before Operation.....	42
4.8.3	Constant Voltage Check (Standard Master Power Supply) .....	42
4.8.4	Constant Voltage Check (Blank Panel Master Power Supply) .....	43
4.8.5	Constant Current Check (Standard Master Power Supply) .....	43
4.8.6	Constant Current Check (Blank Panel Master Power Supply) .....	44
4.9	Connecting the Load .....	44
4.9.1	Load Wiring.....	45
4.9.2	Current Carrying Capacity.....	45
4.9.3	Wire Termination.....	47
4.9.4	Inductive Loads and Stored Energy Loads .....	47
4.9.4.1	Blocking and Antiparallel Diodes .....	47
4.9.5	Making the Load Connections .....	48
4.9.6	Grounding Outputs .....	51
4.10	Local and Remote Sensing .....	52
4.10.1	Sense Wiring .....	52
4.10.2	Local Sensing.....	52
4.10.3	Remote Sensing .....	52
4.10.4	J8 Sense Connector.....	52
4.10.5	Remote Sense Connection.....	53
<b>CHAPTER 5: SPECIFICATIONS .....</b>		<b>54</b>
5.1	30kW Series Specifications.....	54
5.2	45kW Series Specifications.....	57
5.3	45kW: 1000V and 1500V Series Specifications .....	60
5.4	60kW Series Specifications.....	63
5.5	67.5kW Series Specifications.....	66
5.6	90kW Series Specifications.....	69

## GENERAL INFORMATION

The documentation (including this manual) is subject to change without notice. Refer to the TDK Product Center for up-to-date documentation and user manuals for optional communication interfaces (including MODBUS-TCP, EtherCAT, and EtherNet/IP):

[https://product.tdk.com/en/search/power/switching-power/prg-power/tec\\_data/ps\\_system\\_genesys\\_plus](https://product.tdk.com/en/search/power/switching-power/prg-power/tec_data/ps_system_genesys_plus)

Drivers and GUIs are updated periodically to support new features. Refer to the TDK Product Center for up-to-date drivers and GUIs:

[https://product.tdk.com/en/products/power/switching-power/prg-power/designtool/software\\_vcp.html](https://product.tdk.com/en/products/power/switching-power/prg-power/designtool/software_vcp.html)

## WARRANTY

This TDK-Lambda product is warranted against defects in materials and workmanship for a period of five years from the date of shipment. During the warranty period, TDK-Lambda will, at its option, either repair or replace products which prove to be defective.

### Limitation of Warranty

The warranty shall not apply to defects resulting from improper or inadequate usage or maintenance by the buyer, buyer supplied products, or interfacing. The warranty shall not apply to defects resulting from unauthorized modifications or from operation exceeding the environmental specifications of the product or if the QA seal has been removed or altered by anyone other than TDK-Lambda authorized personnel. TDK-Lambda does not warrant the buyers' circuitry or malfunctions of TDK-Lambda products resulting from the buyers' circuitry. Furthermore, TDK-Lambda does not warrant any damage occurring as a result of the buyers' circuitry or the buyers' supplied products. No other warranty is expressed or implied.

### Warranty Service

This product must be returned to an authorized TDK-Lambda service facility for repairs or other warranty service. For products returned to TDK-Lambda for warranty service, the buyer shall prepay shipping charges to TDK-Lambda, and TDK-Lambda shall pay the shipping charges to return the product to the buyer. Refer to Section 4.4 for information on re-packing for shipment.

### Disclaimer

The information contained in this document is subject to change without notice. TDK-Lambda shall not be liable for errors contained in this document or for incidental or consequential damages in connection with the furnishing, performance, or use of this material. No part of this document may be photocopied, reproduced, or translated into another language without the prior written consent of TDK-Lambda.

**ENVIRONMENTAL COMPLIANCE**

TDK-Lambda recognizes its duty and responsibilities towards promoting a sustainable environment. Our policy is to comply with applicable global legislation and to follow TDK Corporation Environmental Policy which goes beyond mandatory International laws.

For additional environmental information, refer to the TDK-Lambda environmental compliance web page at [https://www.emea.lambda.tdk.com/environment\\_policy](https://www.emea.lambda.tdk.com/environment_policy). This page contains the environmental regulations and directives with which TDK-Lambda complies, as well as other environmental information not included in this document.

**Waste Electrical and Electronic Equipment (WEEE)**



EU Customers: At the end of the product life cycle, all products must be sent to a WEEE recycling center.

**China ROHS**

产品 / Product: G+ Power System Series

Date: 11 Dec 2025

**产品中有害物质的名称及含有信息表**



**Information on the Name and Content of Hazardous Substances in Products**

部件名称 / Part Name	有害物质 / Hazardous Substances									
	Pb	Hg	Cd	Cr6+	PBB	PBDE	DBP	DIBP	BBP	DEHP
电路组件/PCB Assembly	X	O	O	O	O	O	O	O	O	O
配件/Accessories	X	O	O	O	O	O	O	O	O	O

注1: O: 表示该有害物质在该部件所有均质材料中的含量均不超出电器电子产品有害物质限制使用国家标准要求。  
 X: 表示该有害物质至少在该部件的某一均质材料中含量超出电器电子产品有害物质限制使用国家标准要求。  
 注2: 以上未列出的部件, 表明其有害物质含量均不超出电器电子产品有害物质限制使用国家标准要求。

Note 1: O: Indicates that the content of the hazardous substance in all homogeneous materials of the component does not exceed the national standard requirements for the restriction of the use of hazardous substances in electrical and electronic products.  
 X: Indicates that the content of the hazardous substance in at least one homogeneous material of the component exceeds the national standard requirements for the restriction of the use of hazardous substances in electrical and electronic products.  
 Note 2: For components not listed above, it means that the content of their hazardous substances does not exceed the national standard requirements for the restriction of the use of hazardous substances in electrical and electronic products.

## **INTENDED USE**

This product is a professional equipment intended for use in an industrial or laboratory environment for generating DC output power within the limits of each model's input and output specifications.

It is NOT intended for home use.

This equipment is intended for use by a professional, trained, or knowledgeable person who has received satisfactory training to be qualified to use this equipment.

This equipment must be operated within its rated environmental conditions to ensure optimal functioning.

Any breach or violations of INTENDED USE could lead to malfunction and/or impairment of the protection provided by the equipment, in which case the manufacturer is not responsible for any of the damages caused.

## **LIFTING AND CARRYING**

This equipment is not intended for lifting or carrying, as it is a heavy equipment and can weigh up to 200Kg (440 pounds). Please use the castors on the equipment for moving it.

## **NORMAL POSITION USE**

This equipment is to be placed and operated on a flat, horizontal floor. The castors must be in lock position with the adjustable feet on the ground at all times unless the equipment is being moved to another location.

## **INSULATION REQUIREMENTS**

All wires and cables connected to the power system must have adequate insulation capable of withstanding elevated temperatures, current through conductors, and all mechanical and electrical stresses applied by the power system or the end application. The ambient temperature of the specific connection must also be considered in accordance with local electricity standards, rules and regulations.

## **LONG-TERM STORAGE METHOD AND LONG-TERM STORAGE PERIOD**

1. Keep the product in its carton box.
2. Do not apply excessive vibration, shock, or mechanical stress to the product.
3. Keep the product away from direct sunlight.
4. Use the following storage conditions as a guideline:
  - Temperature range: 5°C–30°C.
  - Humidity range: 40%RH–60%RH.
5. Keep the product away from places where temperature and humidity can change drastically. It can cause condensation on the product or deterioration of the product.
6. There is a tendency that the leakage current of an aluminum electrolytic capacitor may increase when not used for a long time. This phenomenon can be improved by applying voltage to the aluminum electrolytic capacitor to reduce the leakage current through the self-recovery effect of the electrolyte.

For reference, before using products that have been stored for 1 year or longer, it is recommended to turn on the product using the following conditions:

Input voltage: nominal.

Load: 0 Amperes (no load condition).

Ambient temperature: normal temperature.

Time: 30 minutes or more.

---

**SAFETY AND EMC APPROVALS****SAFETY/EMC Approvals**

IEC 61010-1 - CB Test Report and Certificate.

EN 61010-1 - CE Mark.

IEC/EN 61204-3 - Industrial environment.

Marking of the CE symbol indicates compliance to the EMC Directive, the Low Voltage Directive and RoHS Directive of the European Union.

CE "Declaration of Conformity" in accordance with the preceding directives and standards has been made and is available on a file at our EU representative TDK-Lambda Europe GmbH, Karl-Bold-Str. 40, Achern.

UKCA Marking, when applied to a product covered by this handbook, indicates compliance with the Electrical Equipment (safety) Regulations 2016, Electromagnetic Compatibility Regulations 2016 and Restriction of the Use of Certain Hazardous Substances in Electrical & Electronic Equipment regulation 2012.

UKCA "Declaration of Conformity" in accordance with the preceding directives and standards has been made and is available on a file at our UK representative TDK-Lambda UK Limited, Kingsley Avenue, Ilfracombe, Devon EX34 8ES.

Declarations may be accessed via the company web site:

[https://product.tdk.com/en/search/power/switching-power/prg-power/tec\\_data/ps\\_system\\_genesys\\_plus](https://product.tdk.com/en/search/power/switching-power/prg-power/tec_data/ps_system_genesys_plus)

**WARNING**

This product is designed for an industrial environment. In a residential, commercial or light industrial environment it may cause radio interference. The user may be required to take adequate measures to reduce interference.

**NOTE**

This product is a professional equipment, which is not intended for sale to generic public.

**FCC Notice**

This device complies with Part 15 of the FCC rules. The operation is subject to the following two conditions: (1) this device may not cause harmful interference, and (2) this device must accept any interference received, including interference that may cause undesired operation.

**NOTE**

This equipment has been tested and found to comply with the limits for a Class A digital device pursuant to part 15 of the FCC rules. These limits are designed to provide reasonable protection against harmful interference when the equipment is operated in a commercial environment.

This equipment generates, uses, and can radiate radio frequency energy. If not installed and used in accordance with the instruction manual, it may cause harmful interference to radio communications.

Operation of this equipment in a residential area is likely to cause harmful interference, in which case the user will be required to correct the interference at his own expense.

**WARNING**

Modifications not expressly approved by the party responsible for compliance could void the users' authority to operate the equipment under FCC rules.

## GENERAL SAFETY INFORMATION



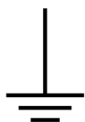
### READ SAFETY INSTRUCTIONS

The following safety precautions must be observed during all phases of operation, service, and repair of this equipment. Failure to comply with the safety precautions or warnings presented in this document violates safety standards of design, manufacture and intended use of this equipment and may impair the built-in protections within. TDK-Lambda shall not be liable for user's failure to comply with these requirements.

### SYMBOLS AND MARKING ON EQUIPMENT



Caution, risk of danger. When this symbol appears on the equipment, it is important to consult the safety manual to preserve safe operation of the equipment and avoid any potential injury or hazard.



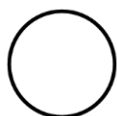
Earth (ground) terminal.



Protective conductor terminal. This is the terminal which is intended for connection to an external conductor for protection against electric shock in case of a fault.



Switch ON position. Powers ON the power system.



Switch OFF position. Powers OFF the power system. **IMPORTANT:** This is NOT the main disconnect device of the equipment. Refer to "DISCONNECT DEVICE" section to learn about the main disconnect device.



Direct current (DC). Indicates that the value next to this symbol is of DC nature.



Alternate current (AC). Indicates that the value next to this symbol is of AC nature.

### SERVICING

These products are not customer serviceable. Parts substitutions and modifications are by authorized TDK-Lambda service personnel only. For repairs or modifications, the product must be returned to TDK-Lambda service facility.

### PRODUCT USAGE

These products are designed for use as standalone equipment within the limits described in the safety and installation manual. They are not designed for general home or consumer use and are designed for indoor use.

**ENVIRONMENTAL**

These products are IP20, and therefore chemicals/solvents, cleaning agents and other liquids must not be used.

**ENVIRONMENT**

These products are designed for use within a Pollution Degree 2, Overvoltage Category II environment, and must be operated within the environmental conditions (temperature, altitude, etc.) specified in the safety and installation manual.

**OUTPUT LOADING**

The output power taken from the product must not exceed the rating stated on the product label, except as stated in the safety and installation manual. The insulation of the wire connected to the DC output should be in accordance with the output load current and voltage.

**INPUT PARAMETERS**

These products must be operated within the input parameters stated in the safety and installation manual. The means of connecting this equipment to the supply must only be according to the instructions specified in the safety and installation manual to reduce risk of hazard.

**EQUIPMENT OPERATION AND OPERATING CONTROLS**

The identification and description of operating controls and their use in all operating modes are stated in the user manual (IA761-04-02\_). The operation of the equipment is explained in detail in the user manual.

**VENTILATION**

The ventilation openings on these products must not be covered. Ensure that there is at least 10cm spacing between any obstruction and the ventilation openings.

**INPUT AND OUTPUT CABLES**

Use cables with the appropriate voltage and temperature ratings to ensure safe, reliable operation.

**ACCESSORIES**

Only accessories that meet the manufacturer's specifications must be used. For identification and instructions for the connection of accessories, refer to the safety and installation manual.

**INSTALLATION**

The installation of the equipment or the system incorporating the equipment must be in accordance with the installation instructions provided by the manufacturer. The safety of any system incorporating the equipment is the responsibility of the assembler.

**USERS**

This equipment must be operated by qualified personnel, who understand the instructions and safety manuals provided with the equipment. The personnel must use the designated and recommended safety equipment. If the equipment must be operated by unqualified personnel, then they must be supervised by qualified personnel.

**RISK OF ELECTRIC SHOCK****HIGH VOLTAGE WARNING**

Dangerous voltages are present within the power system. To avoid injuries, always disconnect power, discharge circuits, and remove external voltage sources before touching the components.

**CLASS I WARNING**

The unit is Class I product. To minimize electrical shock hazard, the unit must be reliably earthed and professionally installed. Any interruption of the protective ground conductor or disconnection of the protective earth terminal will cause a potential shock hazard that might cause personal injury. Energy Hazards Warning: The main output of the unit is hazardous energy and must not be user accessible in the end application.

**HAZARDOUS OUTPUT WARNING**

There is a potential shock hazard when using a power system with an output voltage equal to or greater than 60VDC. Do not turn ON power system when output voltage is equal to or greater than 60VDC without output cover slots and rear panel assembled. Turn OFF power system or disconnect power system from AC mains before making or changing any rear panel connection.

## PRODUCT SAFETY INSTRUCTIONS

### CAUTION

The following safety precautions must be followed during all phases of operation, service, and repair of this equipment. Failure to comply with the safety precautions or warnings in this document violates safety standards of design, manufacture and intended use of this equipment and may impair the built-in protections within. TDK-Lambda shall not be liable for user's failure to comply with these requirements.

## OVERVOLTAGE CATEGORY AND ENVIRONMENTAL CONDITIONS

The **GENESYS™** Power System Series have been assigned to Overvoltage category II.

The **GENESYS™** Power System Series units are intended for use in the following operation conditions:

- Indoor use
- Pollution degree 2
- Maximum operational altitude: 3000m above sea level (Refer to product specifications for operating conditions).
- Ambient temperature: 0°C–50°C (Refer to product specifications for operating conditions).

## GROUNDING

This product is a Safety Class I instrument. To minimize shock hazard, the instrument chassis must be connected to an electrical ground. The instrument must be connected to the AC power system mains through a four-conductor power cable (L1, L2, L3, PE) with the ground wire firmly connected to an electrical ground (safety ground) at the power outlet.

For instruments designed to be hard-wired to the supply mains, the protective earth terminal must be connected to the safety electrical ground before another connection is made. Any interruption of the protective ground conductor or disconnection of the protective earth terminal will cause a potential shock hazard. That might cause personal injury.

### WARNING

In order to prevent inadvertent disconnection of the PE/Ground wire, if the input connection is made by a jacketed cord, then the PE/Ground wire must be minimum 10 mm longer than all of the other MAINS current-carrying conductors connected to the equipment. If input connection is made by separate wires, then an appropriate conduit in accordance with local electricity standards, rules and regulations that stretches from the MAINS outlet supply source up to the entry of the Power System must be used.

## LIVE CIRCUITS

Operating personnel must not remove the instrument cover.

No internal adjustment or component replacement is allowed by non-TDK-Lambda qualified service personnel. Never replace components with a power cable connected. To avoid injuries, always disconnect power, discharge circuits, and remove external voltage sources before touching components.

## PARTS SUBSTITUTIONS AND MODIFICATIONS

Parts substitutions and modifications are allowed by authorized TDK-Lambda Ltd. service personnel only. For repairs or modifications, the instrument must be returned to TDK-Lambda Ltd. service facility.

## AC INPUT

The **GENESYS™** Power System Series is designed for use in TN and TT power distribution systems. Do not use AC supply, which exceeds the input voltage and frequency rating of this instrument. The input voltage and frequency ratings of the **GENESYS™** Power System Series are: 190–240VAC, 47/63Hz for **Three Phase 200V models** and 380–480VAC, 47/63Hz for **Three Phase 480V models**. For safety reasons, the mains supply voltage fluctuations should not exceed +/-10% of the nominal voltage. Ensure that under heavy load, the AC voltage supplied to the power system does not fall below the specifications.

## ENERGY HAZARD

The output of **GENESYS™** Power System Series units is capable of providing the hazardous energy. Therefore, the output and connections must not be user accessible. Customer's final equipment needs to provide adequate protection for service personnel against inadvertent contact with output wires.

### WARNING

There is an electric shock hazard when the power system output is adjusted to be equal to or greater than 60VDC. Ensure it is not possible to touch simultaneously both output terminals or one of the output terminals and earth (including the power system's metal enclosure). Ensure it is not possible to touch simultaneously one of the output terminals and metal parts of any external products supplied by the power system when the output is adjusted to be equal to or greater than 60VDC.

### WARNING

There is a potential electrical shock hazard when using a power system with output voltage equal to or greater than 60VDC. Do not turn ON power system when output voltage is equal to or greater than 60VDC without output cover slots and rear panel assembled. Turn OFF the power system or disconnect power system from AC mains before making or changing any rear panel connection.

This page intentionally left blank

---

## CHAPTER 1: GENERAL INFORMATION

### 1.1 User Manual Content

This manual contains the instructions for installing and operating the **GENESYS™** Power System Series. The instructions refer to the standard and Blank Panel power supplies, including the built-in USB, LAN, and RS232/485 serial communications.

For information related to operation with the optional IEEE communication interface, refer to the IEEE chapter in the power supply user manual: IA761-04-02\_.

For information related to operation with the optional IS420 interface, refer to the IS420 chapter in the power supply user manual: IA761-04-02\_.

For information related to operation with the optional MODBUS TCP, EtherCAT, or EtherNet/IP communication interfaces, refer to the MODBUS TCP, EtherCAT, or EtherNet/IP manuals.

### 1.2 Introduction

#### 1.2.1 General Description

**GENESYS™** Power System Series power supplies are wide output range, high performance switching power supplies. The **GENESYS™** Power System Series is power factor corrected and operates from worldwide AC voltage range continuously.

The standard master unit in the power system continuously displays the output voltage and current, and the indicators show the complete operating status of the power system. The Front Panel controls in the standard units allow the user to set the output parameters, the protection levels (Over-Voltage, Under-Voltage, and Foldback), and preview the settings.

The rear panel includes the necessary connectors to control and monitor the operation of the power system by remote analog signals or by the built-in RS232/485 serial communications, USB, and LAN. IEEE, MODBUS TCP, EtherCAT, and EtherNet/IP communications are optional.

#### 1.2.2 Control via Communication Ports

The following basic functional parameters can be programmed via the communication ports:

- Output voltage setting
- Output current setting
- Output voltage measurement
- Output current measurement
- Output on/off control
- Foldback protection setting
- Over-Voltage protection setting and readback
- Under-Voltage protection setting and readback
- Under-Voltage limit setting and readback
- Power supply start up mode (last setting or safe mode)

### **1.2.3 Analog Voltage Programming and Monitoring**

Analog inputs and outputs are provided at the rear panel for analog control of the power system. The output voltage and the current limit can be programmed by analog voltage or by resistor and can be monitored by analog voltage. The power system output can be remotely set to on or off, and analog signals monitor the proper operation of the power system and the mode of operation (CV/CC).

### **1.2.4 Parallel Operation**

**GENESYS™** Power System Series of the same output voltage and current rating can be paralleled in master-slave configuration with automatic current sharing to increase available power. Refer to the power supply user manual (IA761-04-02\_) for operation instructions.

### **1.2.5 Output Connections**

Either the positive or negative terminal may be grounded, or the output may be floated.

Models up to 100VDC rated output shall not float outputs more than +/- 200VDC above/below chassis ground.

Models from 150VDC up to 600VDC rated output shall not float outputs more than +/- 600VDC above/below chassis ground.

Model with 1000VDC rated output shall not float outputs more than +/- 1000VDC above/below chassis ground.

Model with 1500VDC rated output shall not float outputs more than +1500VDC above chassis ground when the negative pole is connected to chassis ground and outputs shall not float more than -1000VDC below chassis ground when the positive pole is connected to chassis ground.

Local or remote sense may be used.

Contact factory for assistance with applications of higher float voltage.

#### **WARNING**

If the power system output reaches 60VDC or above, the system output terminals are hazardous.
---

## 1.3 Accessories

### 1.3.1 Accessories Provided With the Power System

#### 1.3.1.1 Miscellaneous Hardware

Item	Catalog No.	Manufacturer	Quantity				
			30kW	45kW	60kW	67.5kW	90kW
DB-26 Connector	10090769-P264ALF	FCI	1				
DB-15 Backshell (used for DB-26 connector)	86303638BLF	FCI	1				
SEMS Screw	M3X8 Fe Ni	-	2				
Sense Connector (For 45kW:1000V–1500V only, 67.5kW: 1000V–1500V only, and 90kW)	GIC 2,5 HCV/ 3-ST-7,62	Phoenix Contact	-	1	-	1	1
Hex Key 6mm (for 3P 200)	-	-	-	1	-	-	-
Hex Key 8mm (for 3P 200)	-	-	-	-	1	-	-
Hex Key 6mm (for 3P 400)	-	-	-	-	-	-	1
Safety Note Paper	-	-	1				

#### 1.3.1.2 Busbars Screws Kits

Busbars kits accessories are provided according to Table 1-1.

$\frac{\text{kW}}{\text{V}}$	30	45	60	67.5	90
10–20	Kit-1	Kit-1	Kit-1	-	Kit-1 (10V model is not available)
30–40	Kit-2	Kit-2	Kit-2	-	Kit-1
50–100	Kit-3	Kit-3	Kit-3	-	Kit-2 (50V model is not available)
150–600	Kit-4	Kit-4	Kit-4	-	Kit-3
1000–1500	-	Kit-3	-	Kit-3	Kit-3

**Table 1-1: Busbars Screws Kits Definition**

#### Busbars Kit-1

- Hex. screw M12x35-A4-70, Type DIN933, 24 pcs.
- Hex. nut M12 St. St., Type DIN439B, 24 pcs.
- Flat washer M12 St. St., Type DIN125A, 48 pcs.
- Spring washer M12 St. St., Type DIN127B, 24 pcs.

Use a tightening torque of 400–440 lbf-in. (45–50 Nm).

#### Busbars Kit-2

- Hex. screw M12x30-A4-70, Type DIN933, 24 pcs.
- Hex. nut M12 St. St., Type DIN439B, 24 pcs.
- Flat washer M12 St. St., Type DIN125A, 48 pcs.
- Spring washer M12 St. St., Type DIN127A, 24 pcs.

Use a tightening torque of 400–440 lbf-in. (45–50 Nm).

**Busbars Kit-3**

- Hex. screw M10x30-A4-70, Type DIN933, 24 pcs.
- Hex. nut M10 St. St., Type DIN439B, 24 pcs.
- Flat washer M10 St. St., Type DIN125A, 48 pcs.
- Spring washer M10 St. St., Type DIN127B, 24 pcs.

Use a tightening torque of 220–265 lbf-in. (24.9–29.9 Nm)

**Busbars Kit-4**

- Hex. screw M8x25-A4-70, Type DIN933, 8 pcs.
- Hex. nut M8 St. St., Type DIN439B, 8 pcs.
- Flat washer M8 St. St., Type DIN125A, 16 pcs.
- Spring washer M8 St. St., Type DIN127A, 8 pcs.

Use a tightening torque of 106–132 lbf-in. (12–14.9 Nm)

**1.3.2 Optional Accessories**

**1.3.2.1 Serial Link Cables**

- For ordering serial link cables, refer to the user manual (IA761-04-02\_).
- USB/LAN cables are not provided with the power system.

**1.3.2.2 Paralleling Cable**

For ordering paralleling cables, please contact the TDK-Lambda Sales Office.

**1.3.2.3 Air Filter Option Kit**

The usage of the Air Filter Option Kit is based on the customers' needs.

When using the Air Filter Option Kit, the specifications of the power supply remain the same as for the standard power supply, with the exceptions specified in the Air Filter Kit Manual: IA857-04-01\_.

Two Air Filter Option Kits are available:

- For the full panel (with display and front panel control).
- For the blank panel.

Refer to the table for description of the air filter type and number of units required for different systems.

<b>Filter System</b>	<b>(P/N: GSP15kW-AFK) Full Panel</b>	<b>(P/N: GBSP15kW-AFK) Blank Panel</b>
GSPS30kW	1	1
GBSPS30kW	-	2
GSPS45kW	1	2
GBSPS45kW	-	3
GSPS45kW (1000V–1500V)	1	1
GBSPS45kW (1000V–1500V)	-	2
GSPS60kW	1	3
GBSPS60kW	-	4
GSPS67.5kW (1000V–1500V)	1	2
GBSPS67.5kW (1000V–1500V)	-	3
GSPS90kW	1	3
GBSPS90kW	-	4

## CHAPTER 2: FRONT/REAR PANEL CONTROLS AND CONNECTORS

### 2.1 Introduction

The **GENESYS™** Power System Series has a full set of controls, indicators (in the standard units), and connectors that allow the user to set up and operate the unit. Before starting to operate the unit, please read the following sections for an explanation of the functions, controls and connector terminals.

- Section 2.2: Master Unit Front Panel Display and Controls.
- Section 2.3: Master Unit Front Panel Display and Indicators.
- Section 2.4: Master Unit Blank Front Panel Control and Indicators.
- Section 2.5: Master Unit Rear Panel Connections and Connectors.
- Section 2.6: J1 Connector Terminals and Functions.

### 2.2 Master Unit Front Panel Display and Controls

Refer to Figure 2-1 and Table 2-1 for the description of the Master Unit Front Panel Display and Controls.

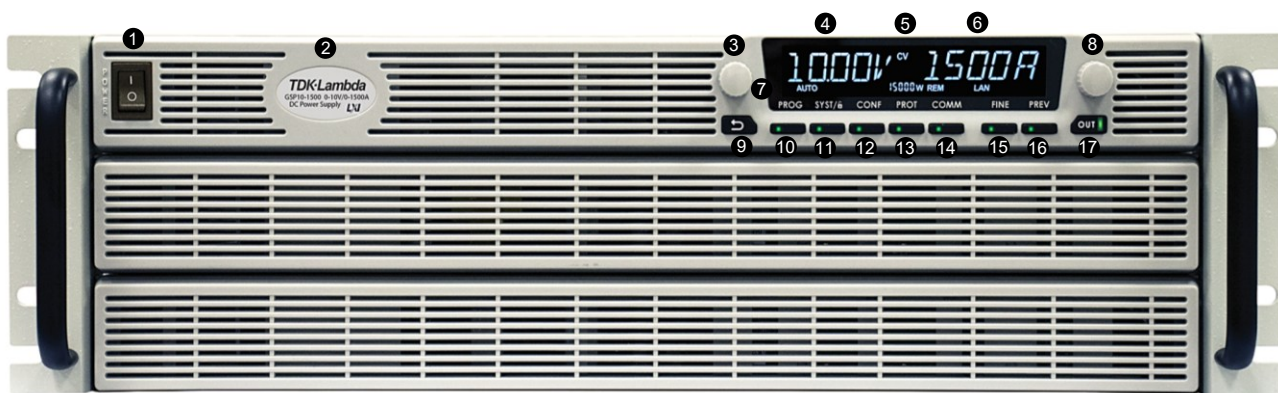


Figure 2-1: Master Unit Front Panel Display and Controls

No.	Control/Indicator	Description
1	Power Switch	POWER ON/OFF control.
2	Power System Model	Model, Voltage, and Current Identifier.
3	Voltage Encoder and Button	Encoder: A high-resolution detent rotary encoder for adjusting the output voltage and navigating the menu. Button: An auxiliary function to accept the voltage-setting value in Preview mode.
4	Voltage Display	4-digit 16-segment Voltage display. Normally displays the output voltage. In Preview mode, the display indicates the setting of the output voltage. In Menu navigation, the display indicates the selected function.
5	Operation Mode Indicator	CV/CC/CP Operation mode indicator.

No.	Control/Indicator	Description
6	Current Display	4-digit 16-segment Current display. Normally displays the output current. In Preview mode, the display indicates the setting of the output current. In menu navigation, the display indicates the selected parameter.
7	Indicators Bar	Refer to the user manual for description of the front panel indicator bar.
8	Current Encoder and Button	Encoder: A high-resolution detent rotary encoder for adjusting the output current and navigating the menu. Button: An auxiliary function to accept the current-setting value, select menu level, and set parameter value.
9	BACK Button	Return one step back in menu navigation mode.
10	PROG Button / Indicator	Activates the Program / Sequencer menu. The Program menu provides Sequencer function control, Trigger function control, and loads a sequence stored inside the power system memory. Green LED lights when Program menu is active. If Program menu is active, press PROG button to exit to the main menu. *
11	SYST / Lock Front Panel Button / Indicator	Activates the System menu. The System menu provides output sensing point selection (Local / Remote sense), Interlock function control, Enable function control, Power Supply OK signal control, SAVE/RECALL power system configuration, Programmable Signals control, Preload function control, Display brightness and dimming function control, and reset power system settings. Green LED lights when System menu is active. If System menu is active, press the SYST button to exit to the main menu. Lock / Unlock Front Panel buttons by pressing the SYST button, followed by pressing of the current encoder. *
12	CONF Button / Indicator	Activates the Configuration menu. The Configuration menu provides power system start mode control, Voltage and Current source control, Analog Programming / Monitoring range selection, Internal Resistance function, Constant Power limit function, and Slew-Rate control function. Green LED lights when the Configuration menu is active. If Configuration menu is active, press the CONF button to exit to the main menu. *
13	PROT Button / Indicator	Activates the Protection menu. The Protection menu provides OVP setting, UVL setting, UVP function control, Foldback function control, and OCL function ON/OFF control. Green LED lights when the Protection menu is active. If Protection menu is active, press the PROT button to exit to the main menu. *
14	COMM Button / Indicator	Activates the Communication menu. The Communication menu provides communication interface selection, power system address selection, LAN settings control, communication baud-rate selection, communication language selection, and software revision information. Green LED lights when Communication menu is active. If Communication menu is active, press the COMM button to exit to the main menu. *

No.	Control/Indicator	Description
15	FINE Button / Indicator	<p>Voltage/Current Fine/Coarse adjustment control. Operates as a toggle switch.</p> <p>In the Fine mode, Voltage and Current encoders operate in high-resolution mode.</p> <p>In the Coarse mode, Voltage and Current encoders operate in standard-resolution mode (approximately 3 turns for full voltage/current rated scale). Green LED lights when the unit is in Fine mode.</p>
16	PREV Button / Indicator	<p>Press the PREV button to display the output Voltage and Current limit settings. The display shows the settings for 5 seconds.</p> <p>If buttons are not pressed for 5 seconds, the display returns back to show actual output voltage and current.</p> <p>If Voltage or Current values are changed, and there is no keypress for 15 seconds, the display returns back to show actual output Voltage and Current. Green LED lights when PREV mode is active.</p>
17	OUT Button / Indicator	<p>Output ON/OFF control. Press OUTPUT to set the output ON or OFF. Green LED lights when DC Output is enabled.</p> <p>Red LED blinks in case of an alarm. Refer to Alarms and Protective Functions section in the user manual: IA761-04-02_.</p>

**Table 2-1: Master Unit Front Panel Display and Controls**

**NOTE**

\* If a menu is active, and there is no key press within 15 seconds, the power system returns to the main display (OFF or actual Voltage and Current display).

## 2.3 Master Unit Front Panel Display and Indicators

Refer to Figure 2-2 and Table 2-2 for the description of the Master Unit Front Panel Display and Indicators.

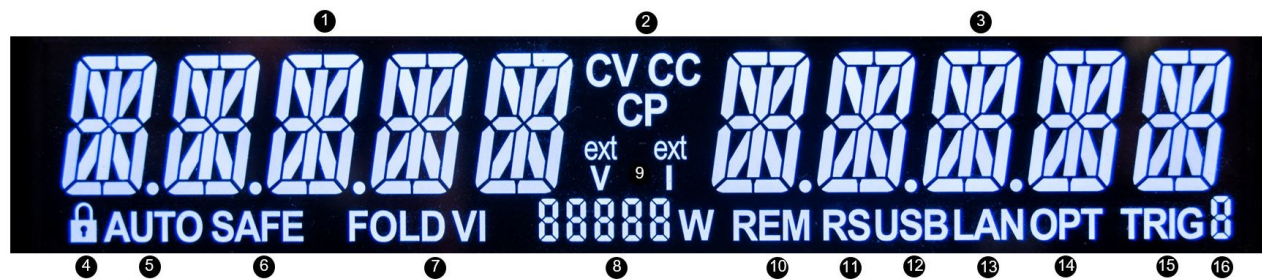


Figure 2-2: Master Unit Front Panel Display and Indicators

No.	Indicator	Description
1	Voltage Display	4-digit 16-segment Voltage display. Normally displays the output voltage. In preview mode, the display indicates the program setting of the output voltage. In menu navigation, the display indicates the selected function.
2	Operation Mode Indicator	CV/CC/CP operation mode indicator.
3	Current Display	4-digit 16-segment Current display. Normally displays the output current. In preview mode, the display indicates the program setting of the output current. In menu navigation, the display indicates the selected parameter.
4	LFP Indicator	Locked Front Panel indicator. LFP is on if the Front Panel is locked.
5	AUTO Indicator	AUTO-Start indicator. AUTO is on if the Auto-Start mode is active.
6	SAFE Indicator	SAFE-Start indicator. SAFE is on if the Safe-Start mode is active.
7	FOLD VI Indicator	Foldback indicator. FOLD V is on if Foldback CV is active. FOLD I is on if Foldback CC is active.
8	Power / Address Indicator	If power supply output is ON, actual output power is displayed. If power supply output is OFF, power supply address is displayed. * The address is displayed while Communication menu is active, regardless of the power supply output state.
9	ext V / ext I Indicators	External Voltage / External Current Analog Programming Indicators. Ext V is on if Analog Voltage Programming channel is active. Ext I is on if Analog Current Programming channel is active.
10	REM Indicator	REMOTE indicator. REM is on if the power supply is controlled by remote communication. (RS232/485, USB, LAN, OPTional).
11	RS Indicator	Recommended Standard indicator. RS232 or RS485 communication type is selected.

<b>No.</b>	<b>Indicator</b>	<b>Description</b>
12	USB Indicator	Universal Serial Bus indicator. USB communication type is selected.
13	LAN Indicator	Local Area Network indicator. LAN communication type is selected.
14	OPT Indicator	Optional communication type indicator. Optional communication type is selected.
15	TRIG Indicator	Trigger indicator. TRIG is on if the trigger-in is enabled and initialized. Power supply is ready to receive trigger-in signal.
16	Active Memory-Cell Indicator	Display active memory cell. 1,2,3,4 – A sequence is loaded from cells 1,2,3 or 4 _ - A sequence is loaded from a PC The indicator is blinking if a sequence is running.

**Table 2-2: Master Unit Front Panel Display and Indicators**

## 2.4 Master Unit Blank Front Panel Control and Indicators

Refer to Figure 2-3 and Table 2-3 for description of the Master Unit Blank Front Panel Control and Indicators.



Figure 2-3: Master Unit Blank Front Panel Control and Indicators

No.	Connection	Description
1	Power Switch	POWER ON/OFF control.
2	Power System Model	Model, Voltage, and Current Identifier.
3	Power LED	Power System ON/OFF status LED. Green LED lights when Power System is ON (Power Switch ON).
4	REM LED	REMOTE status LED. Green LED lights if the power system is controlled by remote communication (RS232/485, USB, LAN, OPTional).
5	OUT LED	Output ON/OFF status LED. Green LED lights when DC Output is enabled. Red LED blinks in case of an alarm. Refer to Alarms and Protective Functions section in the user manual: IA761-04-02_.

Table 2-3: Master Unit Blank Front Panel Control and Indicators

## 2.5 Master Unit Rear Panel Connections and Connectors

Refer to Figure 2-4 and Table 2-4 for description of the Master Unit Rear Panel Connections and Connectors. The below figure shows a High-Voltage (HV) model.

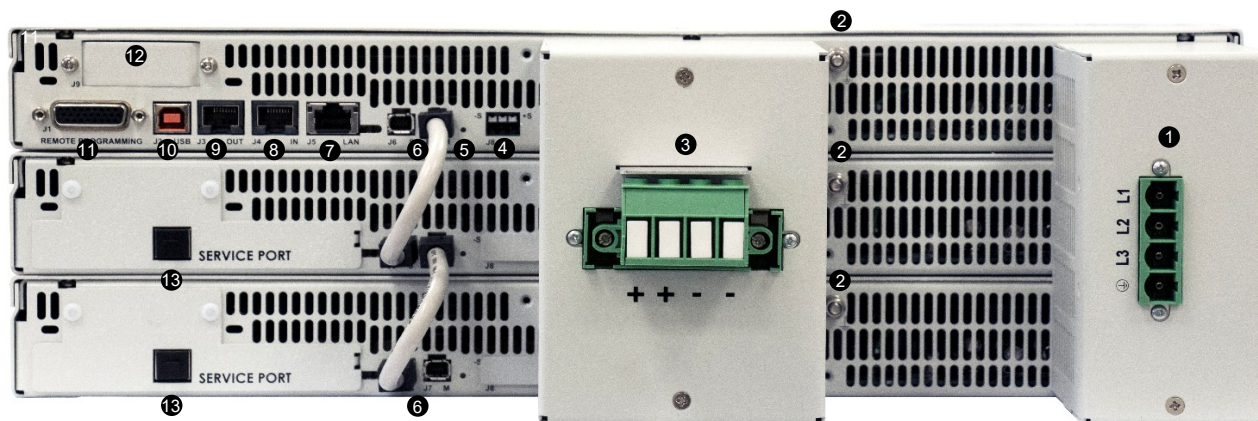


Figure 2-4: Master Unit Rear Panel Connections and Connectors

No.	Connection	Description
1	AC Input Connector	Not accessible for the end-user.
2	Ground Stud	Functional Ground connection, M4x15 Stud.
3	DC output	Not accessible for the end-user.
4	Remote sense connector	Connector for remote sensing connections. Connect to the load for regulation of the load voltage and compensation of load wire drop.
5	Reset button	Set default power supply settings.
6	Paralleling Connectors	Master/Slave connectors, mini I/O type.
7	LAN Connector and Indicators *	LAN interface connector, RJ-45 type + LXI indicators. Connector type: UDE P/N: 26-31024KB91-1.
8	Serial In connector	RJ-45 type connector, used for connecting power supplies to RS232 or RS485 port of a computer for remote control purposes. When using several power supplies in a power system, the first unit Serial-In is connected to the computer and the remaining units are chained, Remote-Out to Remote-In. Connector type: Molex 95540-2881.
9	Serial Out connector	RJ-45 type connector, used for chaining power supplies to/from a serial communication bus. Connector type: Molex 95540-2881.
10	USB Connector	USB interface connector, type B. Connector type: SAMTEC P/N: USBR-B-S-F-O-TH.
11	Isolated control and signals	Isolated analog control and monitoring signals, isolated from the output potential. Connector type: WE P/N: 618026325223.
12	Optional Interface	Position for optional communication interface.
13	Service Port	Service port for factory use. USB interface connector, type B. Connector type: SAMTEC P/N: USBR-B-S-F-O-TH. Located on the Booster units only. (Same location as J2 connector in the first unit.)

Table 2-4: Master Unit Rear Panel Connections and Connectors

**NOTE**

\* LAN Connector LEDs (Green and Amber) and LAN Status Indicator (Red) might light in Power Switch OFF state.

**WARNING**

Refer to the Safety and Installation Manual (IA761-04-01\_) if any connector on the rear panel is connected/disconnected.

**WARNING**

There is a potential electric shock hazard at the output when using a power system with an output equal to or greater than 60VDC. Use wires with minimum insulation rating equivalent to the maximum output voltage of the power system.

## 2.6 J1 Connector Terminals and Functions

Connector Technical Information:

- Connector type: 618026325223, WURTH.
- DB26HD Receptacle type: 10090769-P264ALF, FCI.

Wire: AWG 24–28.

Control and Monitoring signals are SELV.

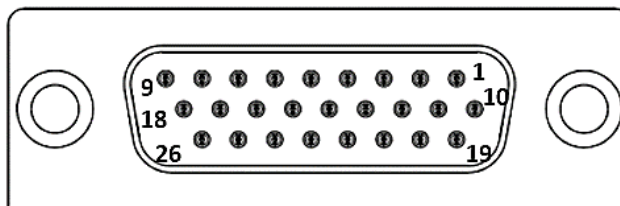


Figure 2-5: J1 Connector Terminals and Functions

No.	Connection	Description
1	Daisy In / SO	Input for Series Operation / Input for Shut Off control of the power supply output.
2	Daisy Out / PS_OK #2	Output for Series Operation / Output #2 for indication of power supply status. High level is OK.
3	PS_OK #1	Output #1 for indication of power supply status. Open Collector type, low level is OK.
4	CV/CC	Output for Constant-Voltage / Constant-Current mode indication.
5	LOC/REM MON	Output for indicating if the unit is in Local (digital) or Remote (analog) programming mode.
6	LOC/REM SELECT	Input for selecting between Local (digital) or Remote (analog) programming of the output Voltage and Current.
7	IPGM	Input for Remote (analog) voltage/resistance programming of the output current.
8	VPGM	Input for remote (analog) voltage/resistance programming of the output voltage.
9	NOT USED	
10	ENA_IN	Enable / Disable the power supply output by dry-contact (short / open) or voltage source. Selectable signal polarity.
11	COM	COMMON. Return for all signals.
12	COM	COMMON. Return for all signals.
13	COM	COMMON. Return for all signals.
14	COM	COMMON. Return for all signals.
15	NOT USED	
16	NOT USED	
17	COM	COMMON. Return for all signals.
18	COM	COMMON. Return for all signals.
19	ILC	Enable / Disable the power supply output by dry-contact (short / open) or voltage source.
20	Programmed Signal 2	General Purpose Open Drain Port 2.
21	Programmed Signal 1	General Purpose Open Drain Port 1.

No.	Connection	Description
22	Trigger In	Power supply trigger input for sequencer operations. Positive edge triggered, pulse width: minimum 10usec.
23	Trigger Out	Trigger output, positive edge, pulse width: minimum. 100usec.
24	NOT USED	
25	I_MON	Output for monitoring the power supply output Current.
26	V_MON	Output for monitoring the power supply output Voltage.

**Table 2-5: J1 Connector Terminals and Functions****CAUTION**

To prevent ground loops and to maintain the isolation of the power system when programming from J1, use an ungrounded programming source.

CHAPTER 3: OUTLINE

FRONT VIEW

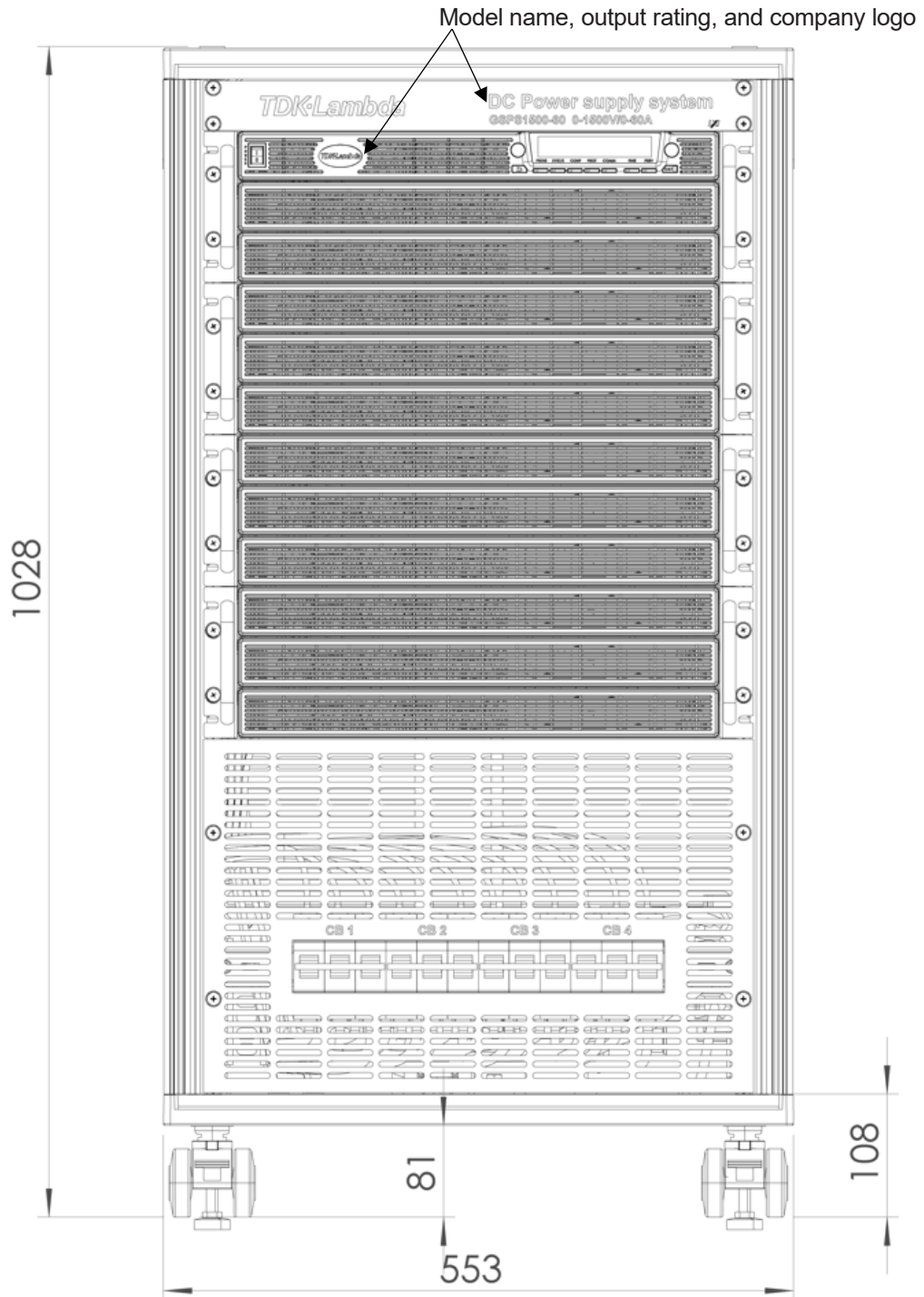


Figure 3-1: GSPS Front View

All dimensions are in mm.

REAR VIEW

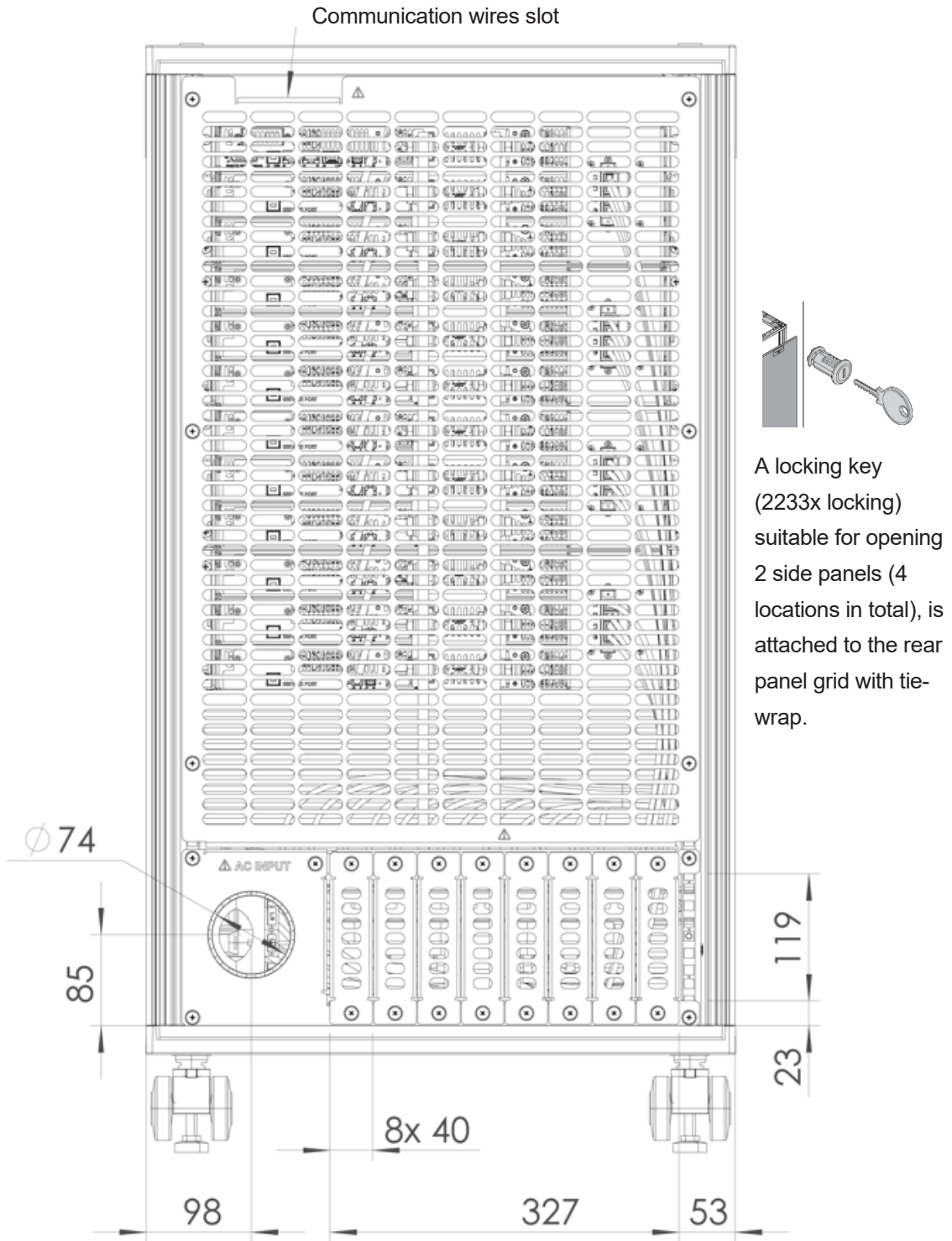
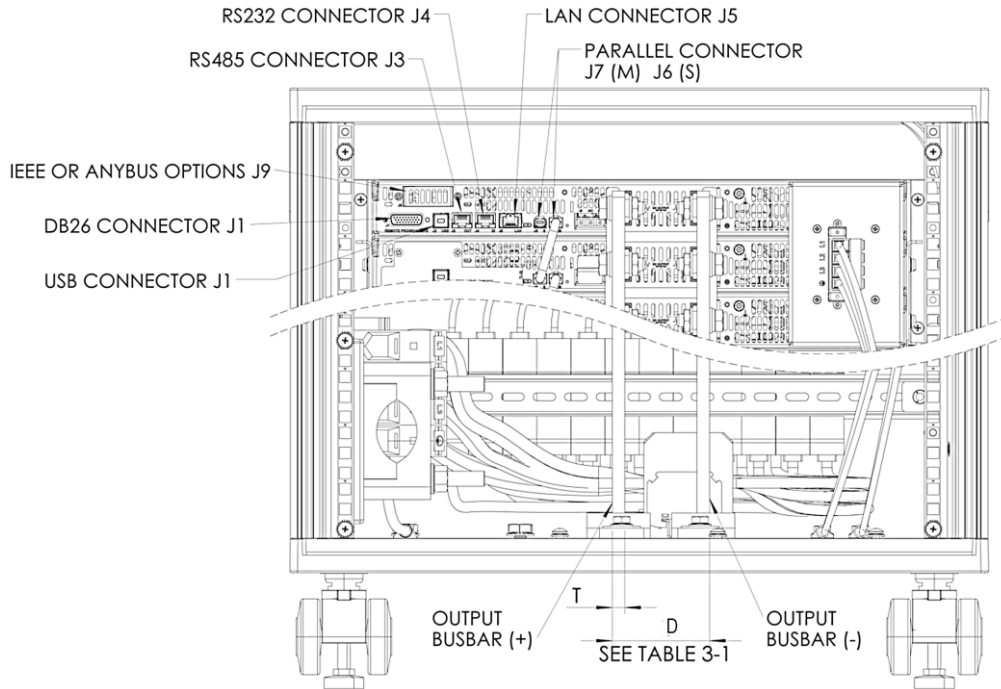


Figure 3-2: GSPS Rear View

All dimensions are in mm.

**REAR INTERNAL VIEW**

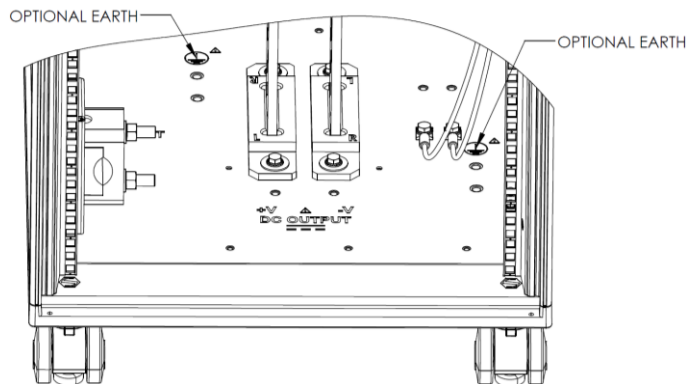


**Figure 3-3: Rear Panel Internal Connections**

Output Voltage	Thickness (T) in mm	Distance (D) in mm
10V–20V	10	77
30V–40V (30kW–60kW)	5	67
30V–40V (90kW)	10	77
50V–100V	5	67
150V–600V (30kW–60kW)	3.5	67
150V–1500V (90kW)	5	67

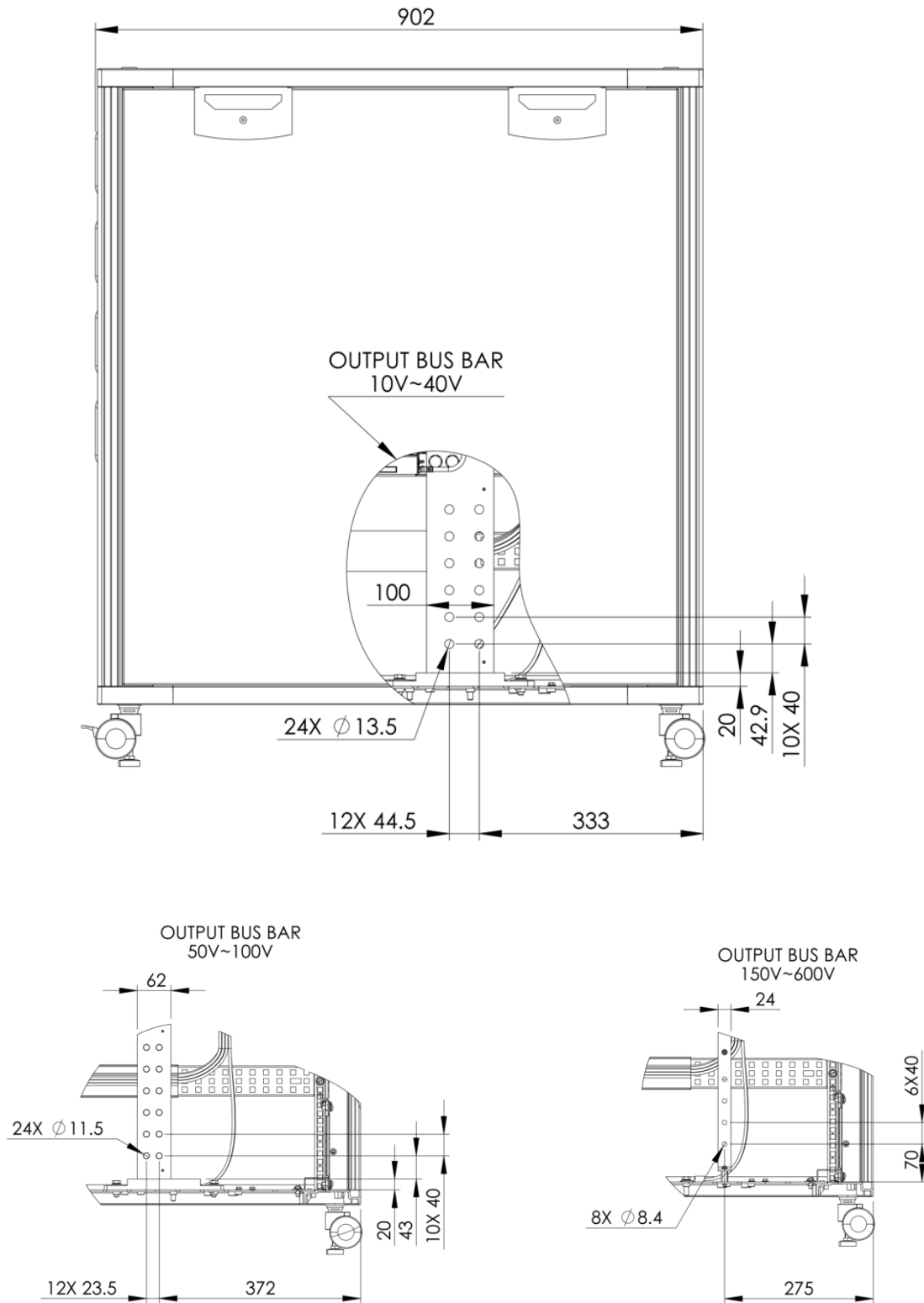
**Table 3-1: Busbars Thickness and Distance**

**OPTIONAL EARTH (GROUND) CONNECTION**



**Figure 3-4: Optional Earth (Ground) Connection**

SIDE VIEW AND BUSBARS DIMENSION



**Figure 3-5: Side View and Bus-bar Dimensions (30kW~60kW)**

All dimensions are in mm.

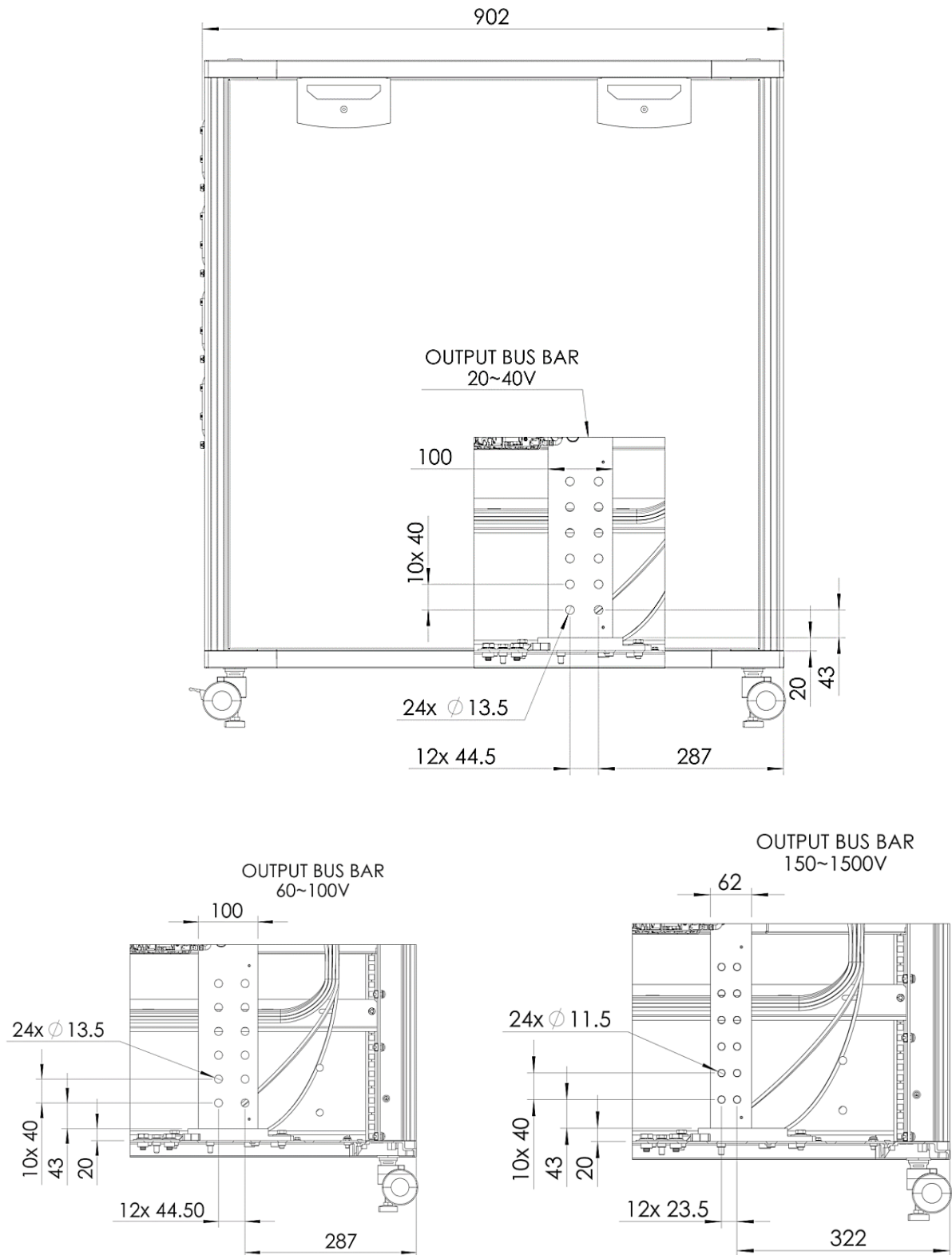


Figure 3-6: Side View and Bus-bar Dimensions (67.5kW-90kW)

All dimensions are in mm.

## 4.1 General

This chapter contains the instructions for initial inspection, preparation for use, and repacking for shipment. Connection to the PC, setting the communication port, and linking **GENESYS™** Power System is described in the user manual.

### CAUTION

Observe all torque guidelines within this manual. Over torque may damage the unit or accessories. Such damage is not covered under the manufacturer's warranty.

### NOTE

**GENESYS™** Power System supplies generate magnetic fields, which might affect the operation of other instruments. If your equipment is susceptible to magnetic fields, do not position it adjacent to the power system.

## 4.2 Preparation for Use

Do not apply power before reading the safety instructions and Section 4.7.

Follow the instructions in Table 4-1 in the sequence given to prepare the power system for use.

Step no.	Item	Description	Reference
1	Unpacking and Initial Inspection	Initial physical inspection of the power system	Section 4.3
2	Location	Location, mounting, and cooling	Section 4.5
3	Installation	Preparing the power system for the connections	Section 4.6
4	AC mains	AC mains requirements. Connecting the power system to the AC mains	Section 4.7
5	Test	Turn-on checkout procedure	Section 4.8
6	Load connection	Wire size selection. Local / Remote sensing. Single or multiple loads	Section 4.9
7	Default setting	The power system's settings at shipment	User Manual

**Table 4-1: Basic Setup Procedure**

## 4.3 Unpacking and Initial Inspection

### CAUTION

To avoid potential personal injury, handling, lifting, and carrying of the equipment shall only be done according to the instructions specified in this section only.

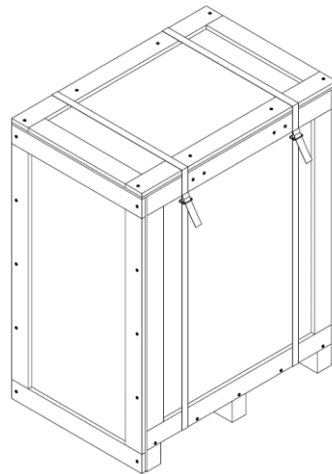
### CAUTION

GSPS/GBSPS power system is considered as a very heavy unit. Follow unpacking instructions carefully to avoid injury and/or damage to the unit.

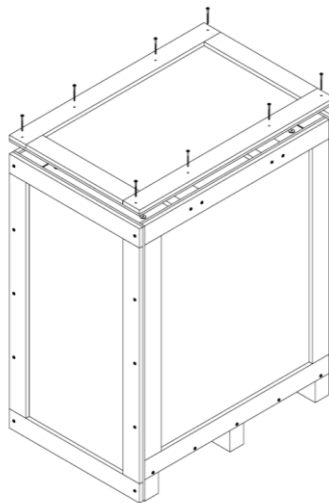
### NOTE

The product was inspected before shipment and found to be free of mechanical or electrical defects.

1. Remove the straps attached to the packaging box.

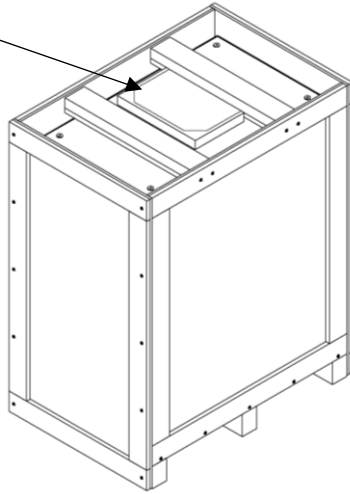


2. Unscrew the fixing screws to disassemble the top cover.

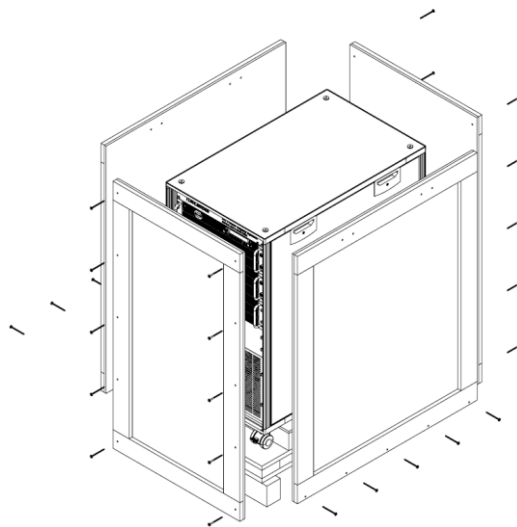
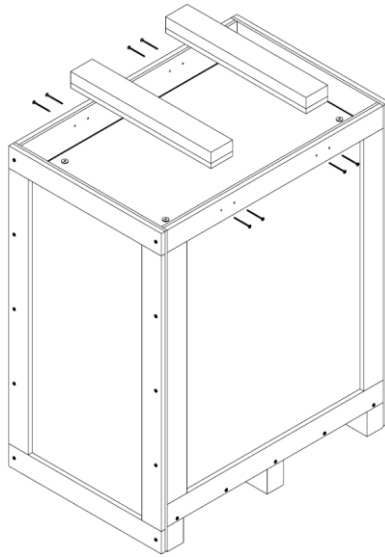


3. Gently remove the accessories box.

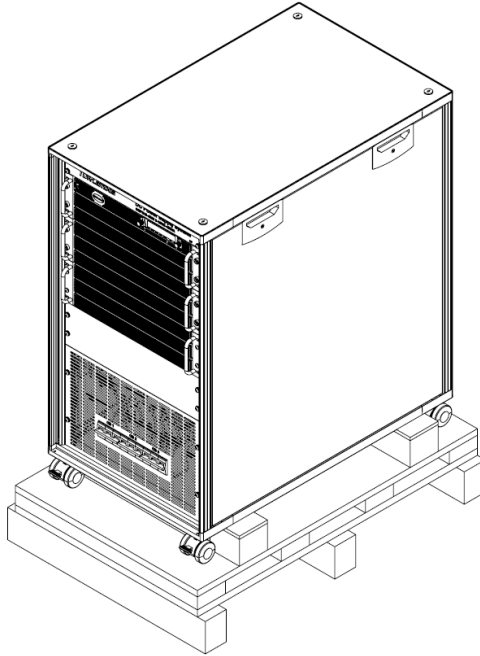
Accessories Box



4. Unscrew the fixing screws to disassemble the reinforcing beams.



5. Unload the Power System from the wooden platform and keep it on a flat ground.



#### **CAUTION**

This equipment is not intended for lifting or carrying. It is a heavy equipment and can weigh up to 200Kg (440 pounds). Please use the castors on the equipment for moving it.

Upon unpacking the power system, inspect for any damage that may have occurred in transit. The inspection should confirm that there is no exterior damage, such as broken knobs or connectors, and that the front panel and meter faces are not scratched or cracked. Keep all packing material until the inspection has been completed.

If damage is detected, file a claim with the carrier immediately and notify the TDK-Lambda sales or service facility nearest you.

## **4.4 Repackaging for Shipment**

To ensure safe transportation of the power system, contact the TDK-Lambda sales or service facility near you for return authorization and shipping information.

Please attach a tag to the power system describing the problem and specifying the owner, model number, and serial number of the power system. Refer to the warranty information for further instructions.

## 4.5 Location, Mounting, and Cooling

The equipment is to be placed and operated on a flat, horizontal floor. The castors must be in lock position with the adjustable feet on the ground at all times unless the equipment is being moved to another location.

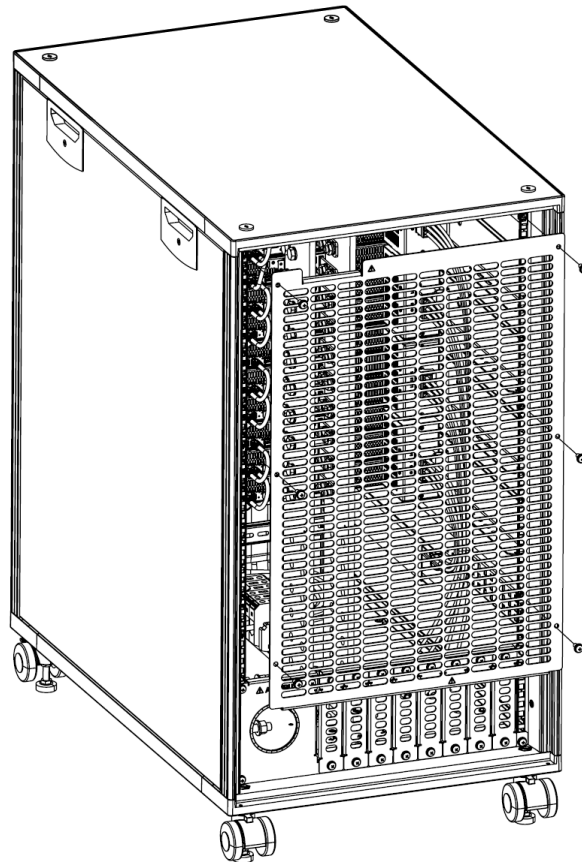
This power system consists of power supplies that are fan cooled. The air intake is at the front panel and the exhaust is at the rear panel. Upon installation, allow cooling air to reach the front panel ventilation inlets.

### CAUTION

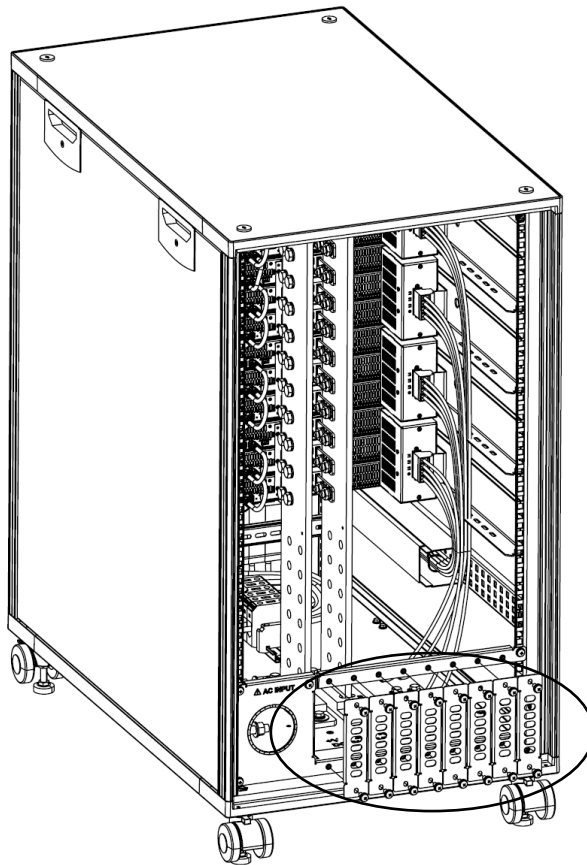
The ventilation openings in this equipment must not be covered. Allow a minimum of 10 cm (4") of unrestricted air space at the front and rear of the unit. The power system should be used in an area where the ambient temperature does not exceed +50°C. (Refer to the product specifications for the operating conditions.)

## 4.6 Preparing the Power System for the Connections

1. Unscrew the fixing screws to remove the rear panel of the cabinet.

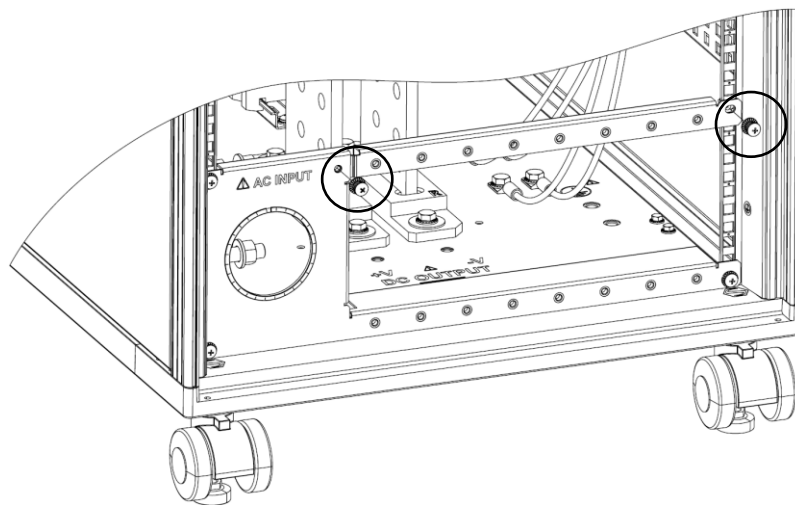


2. Unscrew the fixing screws that are highlighted in Figure 4-1 to remove the rear panel slots of the cabinet.



**Figure 4-1: Unscrew the Fixing Screws**

3. Disassemble the panel by unscrewing the fixing screws that are highlighted in Figure 4-2 to allow easy access into the cabinet.



**Figure 4-2: Disassembling the Panel**

## 4.7 AC Input Power Connection

AC Cables are not provided with the power system. For recommended AC input cables (customer applied), refer to:

- Table 4-2: Recommended AC Input Cables for 30kW.
- Table 4-3: Recommended AC Input Cables for 45kW.
- Table 4-4: Recommended AC Input Cables for 60kW.
- Table 4-5: Recommended AC Input Cables for 67.5kW.
- Table 4-6: Recommended AC Input Cables for 90kW.

AC Input Range	AC Input Cable
190–240Vac, Three phase	<b>(111A)</b> Minimum 4 X 35mm <sup>2</sup> (Three wires plus safety ground), stranded copper, 300V, 105°C minimum, 3m maximum length, outer diameter 33mm.
380–480Vac, Three phase	<b>(55.2A)</b> Minimum 4 X 10mm <sup>2</sup> (Three wires plus safety ground), stranded copper, 600V, 105°C minimum, 3m maximum length, outer diameter 21mm.

**Table 4-2: Recommended AC Input Cables for 30kW**

AC Input Range	AC Input Cable
190–240Vac, Three phase	<b>(166.5A)</b> Minimum 4 X 70mm <sup>2</sup> . Three wires plus safety ground, stranded copper, 300V, 105°C minimum, 3m maximum length, outer diameter 39mm.
380–480Vac, Three phase	<b>(82.8A)</b> Minimum 4 X 25mm <sup>2</sup> . Three wires plus safety ground, stranded copper, 600V, 105°C minimum, 3m maximum length, outer diameter 30mm.

**Table 4-3: Recommended AC Input Cables for 45kW**

AC Input Range	AC Input Cable
190–240Vac, Three phase	<b>(222A)</b> Minimum 4 X 95mm <sup>2</sup> . Three wires plus safety ground, stranded copper, 300V, 105°C minimum, 3m maximum length, outer diameter 48mm.
380–480Vac, Three phase	<b>(110.4A)</b> Minimum 4 X 35mm <sup>2</sup> . Three wires plus safety ground, stranded copper, 600V, 105°C minimum, 3m maximum length, outer diameter 33mm.

**Table 4-4: Recommended AC Input Cables for 60kW**

AC Input Range	AC Input Cable
380–480Vac, Three phase	<b>(121.5A)</b> Minimum 4 X 50mm <sup>2</sup> . Three wires plus safety ground, stranded copper, 600V, 105°C minimum, 3m maximum length, outer diameter 33mm.

**Table 4-5: Recommended AC Input Cables for 67.5kW**

AC Input Range	AC Input Cable
380–480Vac, Three phase	<b>(162A)</b> Minimum 4 X 70mm <sup>2</sup> . Three wires plus safety ground, stranded copper, 600V, 105°C minimum, 3m maximum length, outer diameter 33mm.

**Table 4-6: Recommended AC Input Cables for 90kW**

Power Rating	$I_{max}$ (A)	Cross Sections	
		Cable Clamp Specification (mm)	Minimum Recommended Cable (mm <sup>2</sup> )
30kW 3P208	3x125	KOZ CABLE CLAMP ST 26-38	4x35
45kW 3P208	3x185	KOZ CABLE CLAMP ST 36-52	4x70
60kW 3P208	3x250	KOZ CABLE CLAMP ST 36-52	4x95
30kW 3P480	3x63	KOZ CABLE CLAMP ST 18-26	4x10
45kW 3P480	3x95	KOZ CABLE CLAMP ST 26-38	4x25
60kW 3P480	3x125	KOZ CABLE CLAMP ST 26-38	4x35
67.5kW 3P480	3x135	KOZ CABLE CLAMP ST 26-38	4x50
90kW 3P480	3x162	KOZ CABLE CLAMP ST 36-52	4x70

**Table 4-7: Recommended Wire Specifications for the Cable Clamp**

**CAUTION**

Before starting the installation, confirm that the AC mains meets the equipment's nominal input rating.

**WARNING**

The connection of this power system to AC mains must be made by an electrician or other qualified personnel in accordance with local electricity standards, rules and regulations.

**WARNING**

The power system must be electrically connected to the AC mains by means of a permanent connection which can be detached only by the use of a tool, or by a connector meeting the requirements of a national standard.

**WARNING**

The equipment must be connected to the AC mains through a four-conductor power cable (L1, L2, L3, PE) with the ground (PE) wire firmly connected to an electrical ground (safety ground) at the power outlet.

**WARNING**

There is a potential shock hazard when using the power system without input protection. Do not connect the power system to the AC mains without the input protection properly assembled.

**WARNING**

There is a potential shock hazard if the power system's rear cover is not assembled and fixed with screws. The AC input cover panel and output slots covers must be assembled during the AC mains and system operation.

**WARNING**

There is a potential shock hazard if the power system is not connected to an electrical safety ground via the safety ground terminal in the AC input connector.

**WARNING**

Dangerous voltages are present within the power system. Some components inside the power system are at AC voltage even when the ON/OFF switch is in the OFF position. To avoid an electric shock hazard, disconnect the AC cord and load, discharge circuits, remove external voltage sources and wait for two minutes before removing the cover.

**WARNING**

The power system ON/OFF switch is not the main **disconnect device** and does not completely disconnect all the circuits from the AC mains. The power system has circuit breakers, and they are the main disconnect device that disconnects all supply lines simultaneously.

It is prohibited to position the equipment so that it is difficult to operate the disconnecting device.

Note that circuit breakers in the building must also be installed in order to disconnect power between the outlet and the supply side of the power system's circuit breaker. This building circuit breaker must be suitably located, easily reached, and marked as the disconnect device for this equipment.

**CAUTION**

It is forbidden to solder the conductors. The solder tin yields and fractures under high pressure. The result is increased contact resistance and an excessive temperature rise. In addition, corrosion caused by pickling or fluxes has been observed on soldered conductor ends. Notch fractures at the transition point from the rigid to the flexible conductor area are also possible.

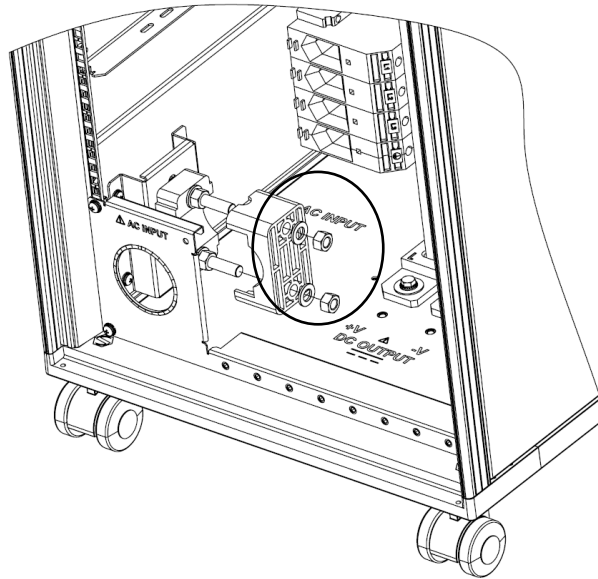
**NOTE**

**AC Input Wires No Conductor Pretreatment:** All kinds of copper conductors can be clamped without pretreatment (solid, flexible, with ferrule, with or without plastic sleeve)

This power system has protective devices (circuit breakers) that disconnect each current-carrying conductor, and they have the following ratings:

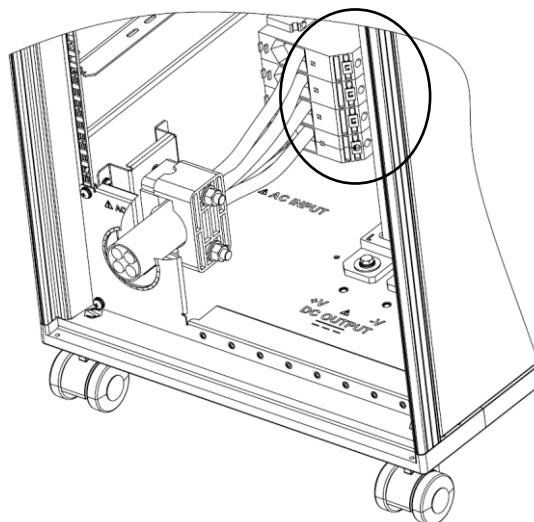
- 2 x 80A for 30kW 3-Phase 208Vac
- 2 x 40A for 30kW 3-Phase 480Vac
- 2 x 80A for 45kW 3-Phase 480Vac for 1000V–1500V models
- 3 x 80A for 45kW 3-Phase 208Vac
- 1 x 80A and 1 x 40A for 45kW 3-Phase 480Vac
- 4 x 80A for 60kW 3-Phase 208Vac
- 2 x 80A for 60kW 3-Phase 480Vac
- 3 x 80A for 67.5kW 3-Phase 480Vac
- 4 x 80A for 90kW 3-Phase 480Vac

1. Loosen the tightening nuts on the cable clamp as highlighted in Figure 4-3 to pass the AC cable.



**Figure 4-3: Loosening the cable clamp**

2. Insert the AC wires into the AC input connector as highlighted in Figure 4-4.  
AC input connector: UKH50/95/240-Phoenix Contact
3. Tighten the screws on the AC input connector using the following tightening torques:
  - 30KW 3P208/480, 45KW 3P480, 60KW 3P480: 65–70 lbf-in. (7.3–8.5Nm)
  - 45KW 3P208: 165–177 lbf-in. (18.5–20Nm)
  - 60KW 3P208: 250–265 lbf-in. (28.3–30Nm)
  - 67.5KW 3P480: 165–177 lbf-in. (18.5–20Nm)
  - 90KW 3P480: 165–177 lbf-in. (18.5–20Nm)
4. Tighten the tightening nuts on the cable clamp



**Figure 4-4: AC Wire Inserted and fixed to the AC Connector**

## 4.8 Turn-On Check Procedure

### WARNING

There is a potential electrical shock hazard when using a power system without output protection. Do not turn ON power without output protection properly assembled. To avoid an electric shock hazard, disconnect the AC cord and load, discharge circuits, remove external voltage sources before making or changing any rear panel connection.

### WARNING

The side panels (on both the left and the right side) must be in the LOCK position at all times to prevent access to hazardous parts and sections.

### 4.8.1 General

The following procedures may be used as a basic incoming inspection check that ensures that the power system is operational. Refer to Figure 2-1 and Figure 2-4 for the location of the controls indicated in the procedure.

### 4.8.2 Before Operation

1. Turn OFF the power switch.
2. Ensure that the protection for the output terminals is mounted and assembled properly.
3. Connect the unit to the AC mains.
4. Connect a DVM with appropriate cables for the rated voltage to the output terminals.
5. Turn ON the power switch. All LCD display segments and LEDs illuminate momentarily.
6. Ensure that the power system is configured to the default setting. (Refer to Section: Parameter Setting Memory in the user manual (IA761-04-02\_)). The LCD display shows: "OUT OFF" (not applicable to the blank panel master power supply).

### 4.8.3 Constant Voltage Check (Standard Master Power Supply)

1. Turn on the output by pressing the OUT button. The OUT LED illuminates.
2. Observe the power system Voltage display and rotate the Voltage encoder.
3. Ensure that the output voltage varies while the Voltage encoder is rotated. The control range is from zero to the maximum rated output for the power system model.
4. Compare the DVM reading with the front panel Voltage display to verify the accuracy of the Voltage display.
5. Ensure that the front panel CV indication on the LCD screen is active.
6. Turn OFF the power switch.

---

#### 4.8.4 Constant Voltage Check (Blank Panel Master Power Supply)

1. Connect a USB cable from a PC to J2 (USB interface connector). Refer to Figure 2-4 and Table 2-4.
2. Turn ON the power switch
3. Run a terminal communication software and send the following commands to turn the power supply output to ON:  
INST:NSEL 6  
OUTP 1  
\*Remember to use Carriage Return character (ASCII 13, 0x0D) after each command.
4. Ensure that the output voltage varies while sending VOLT <XX>\* command. The control range is from zero to the maximum rated output for the power system model.  
\*XX - Programmed voltage value.
5. Compare the DVM reading with the power system readback voltage to verify the accuracy of the voltage readback. Send MEAS:VOLT? to read power system output voltage.
6. Turn OFF the power switch.

#### 4.8.5 Constant Current Check (Standard Master Power Supply)

1. Turn ON the power switch.
2. Set the current limit to 20% of rated output current.
3. Turn OFF the power switch.
4. Connect a DVM to the output terminals and ensure that the output terminals shows 0V.
5. Connect a DC shunt across the output terminals. Ensure that the shunt and the wires current ratings are suitable for the set current limit.
6. Connect a DVM to the shunt.
7. Turn ON the power switch.
8. Turn on the output by pressing the OUT button. The OUT LED illuminates.
9. Observe the power system Current display and rotate the Current encoder.
10. Ensure that the output current varies while the Current encoder is rotated. Keep the control range between zero and 20% of rated output current. Do not go beyond 20% of rated output current.
11. Compare the DVM reading with the front panel Current display to verify the accuracy of the Current display.
12. Ensure that the front panel CC indication on the LCD screen is active.
13. Turn OFF the power switch.
14. Remove the shunt from the power system output terminals.

#### 4.8.6 Constant Current Check (Blank Panel Master Power Supply)

1. Turn ON the power switch.
2. Set the current limit to 20% of rated output current.
3. Turn OFF the power switch.
4. Connect a DVM to the output terminals and ensure that the output terminals shows 0V.
5. Connect a DC shunt across the output terminals. Ensure that the shunt and the wires current ratings are suitable for the set current limit.
6. Connect a DVM to the shunt.
7. Connect a USB cable from a PC to J2 (USB interface connector). Refer to Figure 2-4 and Table 2-4.
8. Turn ON the power switch.
9. Run a terminal communication software and send the following commands to turn the power supply output to ON:  
  
INST:NSEL 6  
OUTP 1  
  
\*Remember to use Carriage Return character (ASCII 13, 0x0D) after each command.
10. Ensure that the output current readback varies while sending CURR <YY>\* command. Keep the control range between zero and 20% of rated output current. Do not go beyond 20% of rated output current. Send MEAS:CURR? command to read power supply output current.  
  
\*YY - Programmed current value.
11. Compare the DVM reading with the readback current to verify the accuracy of the digital readback.
12. Turn OFF the power switch.
13. Remove the shut from the power system output terminals.

#### 4.9 Connecting the Load

##### WARNING

There is a potential shock hazard when using a power system with an output voltage equal to or greater than 60VDC. To avoid an electric shock hazard, disconnect the AC cord and load, discharge circuits, remove external voltage sources before making or changing any rear panel connection.

Ensure that the protection of the output plug is mounted properly and assembled for power supplies when the output voltage is equal to or greater than 60VDC.

Ensure that all connections are securely tightened before applying power.

**WARNING**

The output busbars are capable of providing hazardous energy and hazardous voltages may exist at the outputs. To protect personnel against accidental contact with the hazardous voltages or/and hazardous energy, ensure that output protective slots are installed in the output protection assembly in any case of operation, except if separately permitted in other sections in this manual.

**WARNING**

There is a potential shock hazard if the power system's rear cover are not assembled and fixed with screws. Ensure that the output protection slots are mounted and properly assembled.

**4.9.1 Load Wiring**

The following considerations should be made to select the wiring for connecting the load to the power system:

- The current carrying capacity of the wire (refer to Section 4.9.2)
- The insulation rating of the wire should be at least equivalent to the maximum output voltage of the power system.
- The appropriate temperature rating of the wire.
- The maximum wire length and voltage drop (refer to Section 4.9.2)

**4.9.2 Current Carrying Capacity**

Two factors must be considered when selecting the wire size:

- The wires should have enough current carrying capacity to prevent overheating while carrying the power system load current at the rated load, or the current that would flow in the event the load wires were shorted, whichever is greater.
- The wire size should be selected to enable the voltage drop per lead to be less than 1V at the rated current. Although units will compensate for a higher voltage drop in each load wire (refer to the specifications), it is recommended to minimize the voltage drop (1V maximum) to prevent excessive output power consumption from the power system and poor dynamic response to load changes. Please refer to Table 4-8 for the recommended wire types to limit voltage drop in American and European dimensions respectively.

Output current	Recommended wires (mm <sup>2</sup> )	Recommended wires (AWG/°C)	Recommended lugs/Connector
50A–60A	10 For 30kW: 600V, 45kW: 1000V–1500V, and 67.5kW: 1500V	6 AWG/105°C minimum	For 1kW–5kW: 6 AWG Panduit LCMA10-8-C or equivalent
60A–80A	16 For 30kW: 400V and 500V, 45kW: 600V, 67.5kW: 1000V, and 90kW: 1500V	4 AWG/105°C minimum	4 AWG Panduit LCMA16-8-C or equivalent
80A–100A	25 For 45kW: 500V, 67.5kW: 1000V, and 90kW: 1000V	2 AWG/105°C minimum	2 AWG Panduit LCMA25-8-C or equivalent

<b>Output current</b>	<b>Recommended wires (mm<sup>2</sup>)</b>	<b>Recommended wires (AWG/°C)</b>	<b>Recommended lugs/Connector</b>
100A–160A	50 For 60kW: 400V–600V, and 90kW: 600V	"0" AWG/105°C minimum	"0" AWG Panduit LCMA50-8-L or equivalent
160A–260A	95 For 30kW: 150V, 45kW: 200V, 60kW: 300V, and 90kW: 400V	4/0 = 0000/105°C minimum	4/0 = 0000 Panduit LCMA95-8-L or equivalent
260A–500A	95 For 45kW: 150V, and 60kW: 150V and 200V 3 wires per terminal	4/0 = 0000/105°C minimum	4/0 = 0000 Panduit LCMA95-8-L or equivalent
300A–1000A	95 For 30kW: 40V–100V, 45kW: 50V–100V, 60kW: 80V and 100V, and 90kW: 100V, 150V, 200V, and 300V 5 wires per terminal	4/0 = 0000/105°C minimum	4/0 = 0000 (2 In Parallel) Panduit LCC4/0-12-X or equivalent
1000A–1500A	120 For 30kW: 30V, 45kW: 40V, 60kW: 50V–60V, and 90kW: 80V 6 wires per terminal	4/0 = 0000/105°C minimum	4/0 = 0000 Panduit LCC4/0-12-X (two-hole, long barrel lug) or equivalent
1500A–2000A	185 For 30kW: 20V, 45kW: 30V, 60kW: 40V, and 90kW: 60V 6 wires per terminal	400 kcmil/105°C minimum	400 kcmil Panduit LCC400-12-6 (two-hole, long barrel lug) or equivalent
2000A–3000A	150 X 2 In Parallel per busbar hole For 30kW: 10V, 45kW: 20V, 60kW: 20V and 30V, and 90kW: 30V and 40V 12 wires per terminal	300 kcmil/105°C minimum	300 kcmil Panduit LCC300-12-6 (two-hole, long barrel lug) or equivalent
3000A–4500A	240 X 2 In Parallel per busbar hole For 60kW: 10V and 90kW: 20V 12 wires per terminal	500 kcmil/105°C minimum	300 kcmil Panduit LCC500-12-6 (two-hole, long barrel lug) or equivalent

**Table 4-8: Recommended Cable Size for Output Connection**

### 4.9.3 Wire Termination

The wires should be properly terminated with terminals securely attached. DO NOT use non-terminated wires for load connection at the power system.

### 4.9.4 Inductive Loads and Stored Energy Loads

To prevent damage to the power system from inductive voltage kickback, connect an antiparallel diode (freewheel diode) across the load. Ensure that the rating of the diode is greater than the output voltage and current of the power system. Connect the cathode to the positive terminal and the anode to the negative terminal. Refer to Figure 4-5.

In conditions where positive load transients, such as back EMF from a motor might occur or where stored energy such as a battery or large capacitance is present, a blocking diode in series with the output must be connected to protect the power system. Refer to Figure 4-5.

#### CAUTION

For battery, capacitors, and other energy storage applications, a series diode must be connected to prevent damage to the power system.

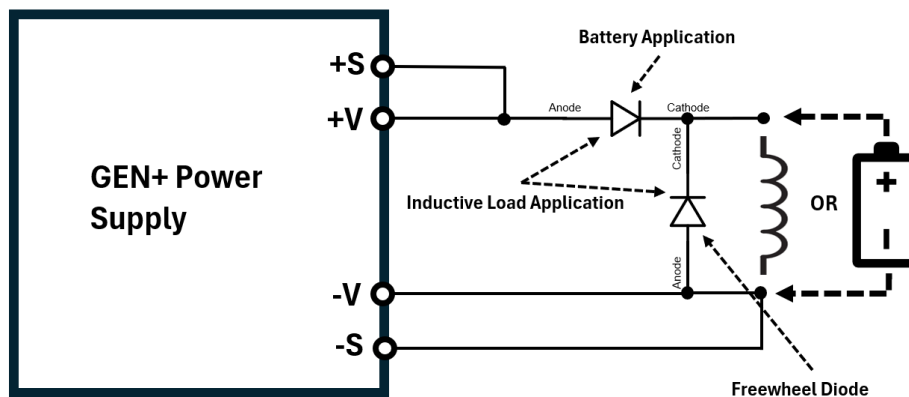


Figure 4-5: Inductive Loads and Stored Energy Loads

#### 4.9.4.1 Blocking and Antiparallel Diodes

Ensure that the chosen components are suitably rated for the inductance and energy to be dissipated. The Peak Reverse Voltage ratings should be at least 2 times the maximum output voltage of the power system. The Continuous Forward Current ratings should be at least 1.5 times the maximum output current of the power system. A heatsink may be required to dissipate the power caused by the flow of current across the diode's forward voltage drop.

**4.9.5 Making the Load Connections****WARNING**

Hazardous voltages exist at power outputs with output equal to or greater than 60VDC. To protect personnel against accidental contact with the hazardous voltages, ensure that the load and its connections have no accessible live parts.

**CAUTION**

Ensure that the load wiring mounting hardware does not short the output terminals. Heavy connecting cables must have some form of strain relief to prevent loosening the connections or bending the busbars.

**CAUTION**

For high current outputs, it is very important to make the output connections properly and follow the instructions. Improper connections may result in excessive temperature rise on the contact points and may overheat the wires of the busbars.

**CAUTION**

The output power taken from the equipment must not exceed the rating stated on the product label, except otherwise stated in this manual. The wires should have a minimum insulation rating equivalent to or greater than the maximum output voltage of the power system.

**CAUTION**

It is forbidden to solder the conductors. The solder tin yields and fractures under high pressure. The result is increased contact resistance and an excessive temperature rise. In addition, corrosion caused by pickling or fluxes has been observed on soldered conductor ends. Notch fractures at the transition point from the rigid to the flexible conductor area are also possible.

**NOTE**

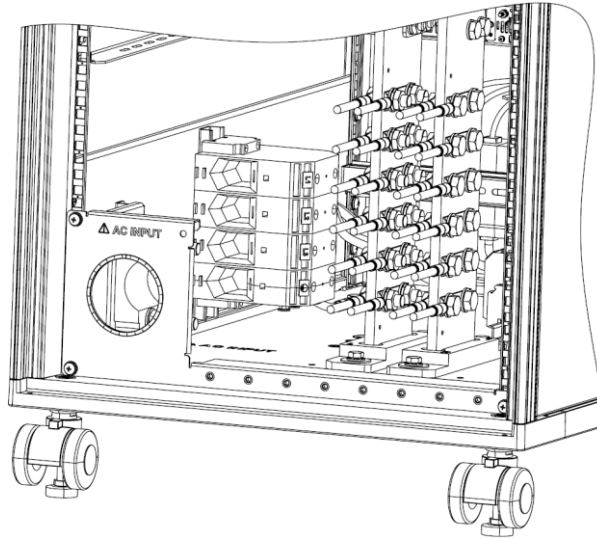
**Output Wires No Conductor Pretreatment:** All kinds of copper conductors can be clamped without pretreatment (solid, flexible, with ferrule, with or without plastic sleeve).

**WARNING**

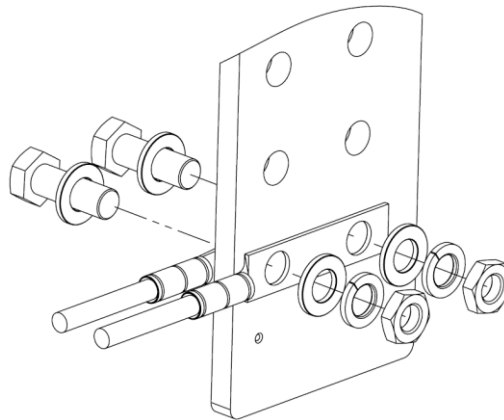
There is a potential shock hazard if the power system's rear cover are not assembled and fixed with screws. The AC input cover panel and output cover slots must be assembled during the AC mains and the system operation.

**For 30kW–60kW: 10V–100V, 45kW–67.5kW:1000V–1500V, and 90kW**

1. Fix the wires to the busbars as shown in Figure 4-6 and Figure 4-7. Refer to Section 1.3.1.2 for torque information.



**Figure 4-6: Output Wires Assembly**

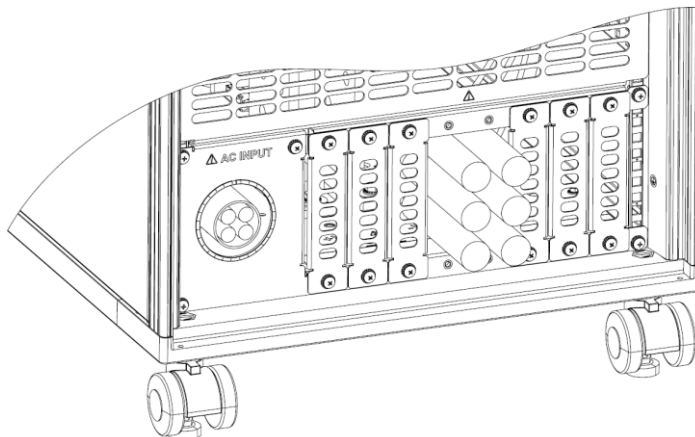


**Figure 4-7: Output Wires Assembly**

**NOTE**

All busbars must be tightened by screw and nut, even if load wire (lug) is not connected.

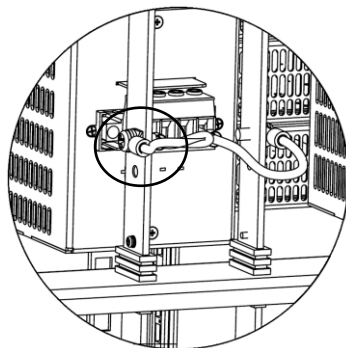
2. Assemble the output protection slots as shown in Figure 4-8.



**Figure 4-8: Assembly of Output Protection Slots**

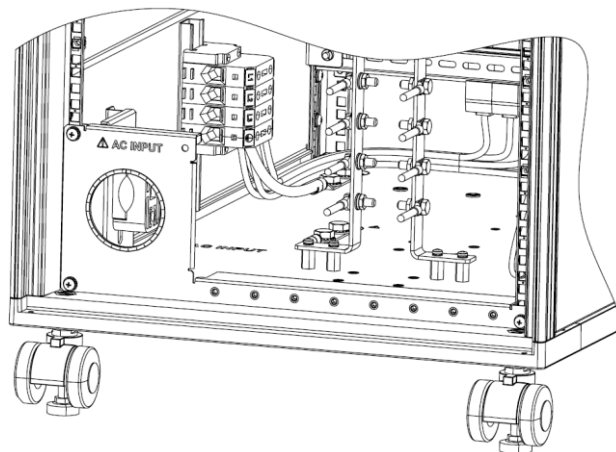
**For 30kW–60kW: 150V–600V**

1. Before first operation, ensure that the M6 screws that connect the power system output to busbars are not loose (General tightening torque is 45–48 lbf.inch (5.1–5.4 Nm). Refer to Figure 4-9.

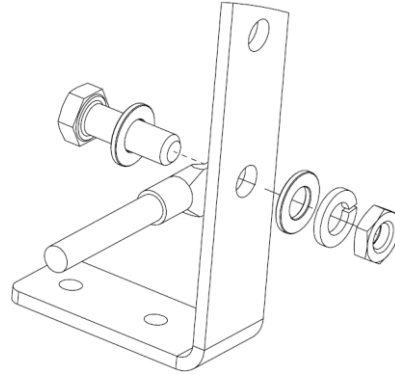


**Figure 4-9: Power Supply Output Screw Connection**

2. Fix the wires to the busbars as shown in Figure 4-10 and Figure 4-11. Refer to Section 1.3.1.2 for torque information.



**Figure 4-10: Output Wires Assembly**

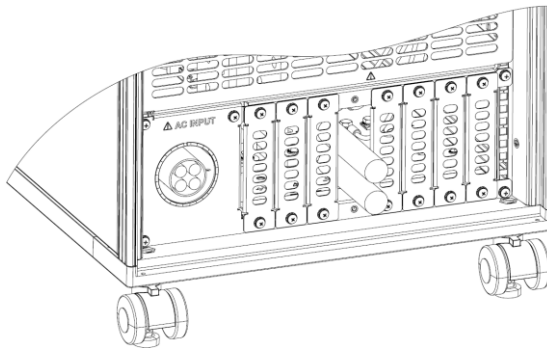


**Figure 4-11: Output Wires Assembly**

**NOTE**

All busbars must be tightened by screw and nut, even if load wire (lug) is not connected.

3. Assembly the output protection slots as shown in Figure 4-12.



**Figure 4-12: Assembly of Output Protection Slots**

#### 4.9.6 Grounding Outputs

Either the positive or negative output terminals can be grounded. To avoid noise problems caused by common-mode current flowing from the load to ground, it is recommended to ground the output terminal as close as possible to the power system chassis ground.

Always use two wires to connect the load to the power system regardless of how the system is grounded.

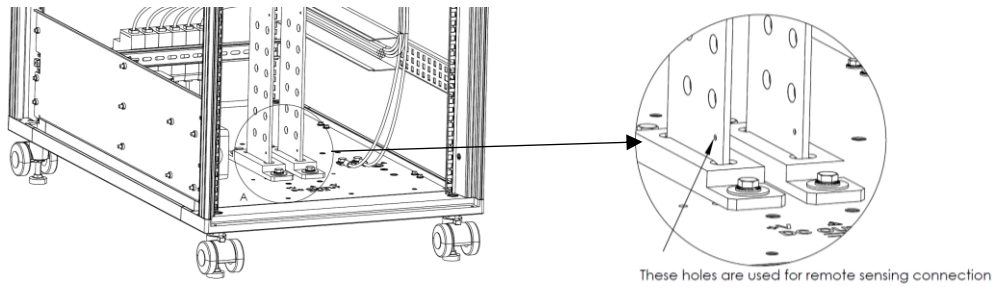
**WARNING**

When using a model with 1500V rated output, there is a potential shock hazard at the RS232/485, LAN, USB, IEEE, Modbus TCP, EtherCAT, IS420, and EtherNet/IP ports when the output voltage is greater than 1000V and the positive output of the power supply is grounded.

## 4.10 Local and Remote Sensing

The J8 sense connector on the rear panel of the master power supply may be used for remote sensing of the output voltage. Refer to Section 2.5 for the location of the sense connector of the master power supply.

Refer to Figure 4-13 for the location of the sense connection on the Power System’s output busbars.



**Figure 4-13: Output Busbars Terminals Location**

### 4.10.1 Sense Wiring

**WARNING**

There is a potential shock hazard at the sense connector when using a power system with an output voltage equal to or greater than 60VDC. Remote sense wires should have a minimum insulation rating equivalent to or greater than the maximum output voltage of the power system. Ensure that the connections at the load end are shielded to prevent accidental contact with the hazardous voltages.

### 4.10.2 Local Sensing

The power system is shipped with an unconnected J8 sense connector on the rear panel of the master power supply. In this configuration, the unit is sensing the output voltage at the output terminals. This method does not compensate for voltage drop on the load wires; therefore, it is recommended only for low load current applications or where the load regulation is less critical.

### 4.10.3 Remote Sensing

Use remote sense where the load regulation at the load end is critical. In remote sense, the power system will compensate for voltage drop on the load wires.

Refer to the CHAPTER 5: SPECIFICATIONS for the maximum allowable voltage drop on load wires. The voltage drop is subtracted from the total voltage available at the output.

### 4.10.4 J8 Sense Connector

Refer to the table for the assignment of J8 sense connector on the rear panel of the master power supply.

Terminal	Function
J8 - (-S)	Remote negative sense.
J8 - (+S)	Remote positive sense.

**For 30kW–60kW series:**

- J8 connector type: SPT-THR 1,5/ 3-H-3,5 P26, Phoenix Contact.
- Wire AWG: 24 up to 18.
- Wire type: Solid, Flexible conductor or conductor with ferrule without plastic sleeve: up to 1.5mm<sup>2</sup>.
- Conductor with ferrule with plastic sleeve: up to 0.75mm<sup>2</sup>.

To connect the wires to the sense connector, strip up to 8mm of wire insulation. Insert the wire into the terminal, while pressing on the white pusher. After full insertion, release the white pusher for locking the wire inside the terminal.

**For 45kW: 1000V–1500V models, 67.5kW: 1000V–1500V models, and 90kW series:**

- J8 Sense plug: GIC 2,5 HCV/ 3-ST-7,62, Phoenix Contact.
- Wire AWG: 24 up to 12.
- Wire type: Solid, Flexible conductor or conductor with ferrule without plastic sleeve: up to 2.5mm<sup>2</sup>.
- Conductor with ferrule with plastic sleeve: up to 2.5mm<sup>2</sup>.

To connect the wires to the sense connector, strip up to 8mm of wire insulation. Insert the wire into the sense plug. Insert the sense plug unto the sense connector.

**4.10.5 Remote Sense Connection**

**CAUTION**

Reversing the sense wires might cause damage to the power system in local and remote sensing. (Do not connect -S to +V or +S to -V.)

When using shielded sense wires, ground the shield in one place only. The location can be the power system chassis or one of the output terminals.

Follow the instructions below to configure the power system for remote sensing:

1. Ensure that the power system is disconnected from the AC mains.
2. Connect the negative sense lead to J8 (-S) terminal and the positive sense lead to J8 (+S) terminal.

**NOTE**

Either the sense terminals of the load or the sense terminals of the power system busbars can be connected to the sense terminals of the J8 connector.

3. Set the sense to remote sense via front panel or communication.
4. Turn ON the power system.

**NOTE**

To ensure correct operation in remote sense mode, ensure that the voltage drop on the sensing wires meets the product specifications.

### 5.1 30kW Series Specifications

Unless otherwise noted, specifications are warranted over the ambient temperature range of 0° to 50° Celsius.

OUTPUT RATING		10-3000	20-1500	30-1020	40-750	50-600	60-510	80-390	100-300	150-204	200-150	300-102	400-78	500-60	600-51
1. Rated output voltage (*1)	V	10	20	30	40	50	60	80	100	150	200	300	400	500	600
2. Rated output current (*2)	A	3000(*3)	1500	1020	750	600	510	390	300	204	150	102	78	60	51
3. Rated output power	W	30000	30000	30600	30000	30000	30600	31200	30000	30600	30000	30600	31200	30000	30600

INPUT CHARACTERISTICS	V	10	20	30	40	50	60	80	100	150	200	300	400	500	600	
1. Input voltage/freq. 3 phase, 3 wire+ground (*4)	---	3-Phase, 200V models: 170~265Vac, 47~63Hz (Covers 200/230Vac). 3-Phase, 480V models: 342~528Vac, 47~63Hz (Covers 380/400/415/440/460/480Vac).														
2. Maximum Input current at 100% load	---	3-Phase, 200V models: 106.8A @ 200Vac. 3-Phase, 480V models: 56.2A @ 380Vac.														
3. Power Factor (Typ.)	---	0.94 @ 200/380Vac, rated output power.														
4. Efficiency (minimum) (*5)	%	87			88			89			90					

CONSTANT VOLTAGE MODE	V	10	20	30	40	50	60	80	100	150	200	300	400	500	600	
1. Max. Line regulation (*6)	---	0.01% of rated output voltage.														
2. Max. Load regulation (*7)	---	0.01% of rated output voltage +5mV.														
3. Temperature coefficient	---	50PPM/°C from rated output voltage, following 30 minutes warm-up.														
4. Temperature stability	---	0.01% of rated Vout over 8hrs. interval following 30 minutes warm-up. Constant line, load & temperature.														
5. Warm-up drift	---	Less than 0.05% of rated output voltage +2mV over 30 minutes following power on.														
6. Remote sense compensation/wire (*8)	V	2	2	5	5	5	5	5	5	5	5	5	5	5	5	
7. Up-prog. response time (*9)	mS	30	30	30	30	50	50	50	50	50	50	50	100	100	100	
8. Down-prog. response time	Full load (*10)	50	50	80	80	80	80	100	100	100	100	100	150	200	200	
	No load (*10)	300	600	800	900	950	1000	1200	1900	2000	2500	3000	4000	4000	3000	
9. Transient response time	---	Time for output voltage to recover within 0.5% of its rated output for a load change 10~90% of rated output current. Output set point: 10~100%, Local sense. Less than 1mS for models up to and including 100V. 2mS for models above 100V.														

CONSTANT CURRENT MODE	V	10	20	30	40	50	60	80	100	150	200	300	400	500	600	
1. Max. Line regulation (*6)	---	0.05% of rated output current.														
2. Max. Load regulation (*11)	---	0.08% of rated output current.														
3. Temperature coefficient	---	10V~100V models: 100PPM/°C from rated output current, following 30 minutes warm-up. 150V~600V models: 70PPM/°C from rated output current, following 30 minutes warm-up.														
4. Temperature stability	---	0.01% of rated Iout over 8hrs. interval following 30 minutes warm-up. Constant line, load & temperature.														
5. Warm-up drift	---	10V~100V models: Less than +/-0.25% of rated output current over 30 minutes following power on. 150V~600V models: Less than +/-0.15% of rated output current over 30 minutes following power on.														

#### ANALOG PROGRAMMING AND MONITORING (ISOLATED FROM THE OUTPUT)

1. Vout voltage programming	---	0~100%, 0~5V or 0~10V, user selectable. Accuracy and linearity: +/-0.15% of rated Vout.														
2. Iout voltage programming (*12)	---	0~100%, 0~5V or 0~10V, user selectable. Accuracy and linearity: +/-0.4% of rated Iout.														
3. Vout resistor programming	---	0~100%, 0~5/10KΩ full scale, user selectable. Accuracy and linearity: +/-0.5% of rated Vout.														
4. Iout resistor programming (*12)	---	0~100%, 0~5/10KΩ full scale, user selectable. Accuracy and linearity: +/-0.5% of rated Iout.														
5. Output voltage monitor (*19)	---	0~5V or 0~10V, user selectable. Accuracy: +/-0.5% of rated Vout.														
6. Output current monitor (*12) (*19)	---	0~5V or 0~10V, user selectable. Accuracy: +/-0.5% of rated Iout.														

#### SIGNALS AND CONTROLS (ISOLATED FROM THE OUTPUT)

1. Power supply OK #1 signal	---	Power supply output monitor. Open collector. Output On: On. Output Off: Off. Maximum Voltage: 30V. Maximum Sink Current: 10mA.														
2. CV/CC signal	---	CV/CC Monitor. Open collector. CC mode: On. CV mode: Off. Maximum Voltage: 30V. Maximum Sink Current: 10mA.														
3. LOCAL/REMOTE Analog control	---	Enable/Disable analog programming control by electrical signal or dry contact. Remote: 0~0.6V or short. Local: 2~30V or open.														
4. LOCAL/REMOTE Analog signal	---	Analog programming control monitor signal. Open collector. Remote: On. Local: Off. Maximum Voltage: 30V. Maximum Sink Current: 10mA.														
5. ENABLE/DISABLE signal	---	Enable/Disable PS output by electrical signal or dry contact. 0~0.6V or short, 2~30V or open. User selectable logic.														
6. INTERLOCK (ILC) control	---	Enable/Disable PS output by electrical signal or dry contact. Output ON: 0~0.6V or short. Output OFF: 2~30V or open.														
7. Programmed signals	---	Two open drain programmable signals. Maximum voltage 25V. Maximum sink current 100mA (shunted by 27V zener).														
8. TRIGGER IN / TRIGGER OUT signals	---	Maximum low level input voltage = 0.8V. Minimum high level input voltage = 2.5V. Maximum high level input = 5V positive edge trigger: tw = 10us minimum. Tr, Tf = 1us maximum. Min delay between 2 pulses 1ms.														
9. DAISY_IN/SO control signal	---	By electrical Voltage: 0~0.6V/2~30V or dry contact.														
10. DAISY_OUT/PS_OK #2 signal	---	4~5V = OK, 0V (500Ω impedance) = Fail.														

**FUNCTIONS AND FEATURES**

1.Parallel operation	---	Consult with Manufacturer.
2.Constant power control	---	Limits the output power to a programmed value. Programming via the communication ports or the front panel.
3.Output resistance control	---	Emulates series resistance. Resistance range: 1~1000mΩ. Programming via the communication ports or the front panel.
4.Slew rate control	---	Programmable Output rise and Output fall slew rate. Programming range: 0.0001~999.99 V/mS or A/mS. Programming via communication ports or front panel.
5.Arbitrary waveforms	---	Profiles of upto 100 steps can be stored in 4 memory cells Activation by command via communication ports or front panel.

**PROGRAMMING AND READBACK (USB, LAN, RS232/485, Optional (\*15) (\*16) (\*17) Interfaces)**

	V	10	20	30	40	50	60	80	100	150	200	300	400	500	600	
1.Vout programming accuracy (*13)	---	0.05% of rated output voltage.														
2.Iout programming accuracy (*12)	---	0.3% of rated output current.														
3.Vout programming resolution	---	0.002% of rated output voltage.														
4.Iout programming resolution	---	0.002% of rated output current.														
5.Vout readback accuracy	---	0.05% of rated output voltage.														
6.Iout readback accuracy (*12)	---	0.2% of rated output current.														
7.Vout readback resolution	% of rated output voltage	0.011%	0.006%	0.004%	0.003%	0.003%	0.002%	0.002%	0.011%	0.007%	0.005%	0.004%	0.003%	0.003%	0.002%	
8.Iout readback resolution	% of rated output current	0.004%	0.008%	0.01%	0.0014%	0.002%	0.002%	0.003%	0.005%	0.005%	0.001%	0.001%	0.0014%	0.002%	0.002%	

**PROTECTIVE FUNCTIONS**

	V	10	20	30	40	50	60	80	100	150	200	300	400	500	600	
1.Foldback protection	---	Output shut-down when power supply changes mode from CV or Power Limit to CC mode or from CC or Power Limit to CV mode. User presetable. Reset by AC input recycle in autostart mode, by Power Switch, by OUTPUT button, by rear panel or by communication.														
2.Over-voltage protection (OVP)	---	Output shut-down. Reset by AC input recycle in autostart mode, by Power Switch, by OUTPUT button, by rear panel or by communication.														
3.Over-voltage programming range	V	0.5~12	1~24	2~36	2~44.1	5~55.125	5~66.15	5~88.2	5~110.25	5~165.37	5~220.5	5~330.75	5~441	5~551.25	5~661.5	
4.Over-voltage programming accuracy	---	+/-1% of rated output voltage.														
5.Output under voltage limit (UVL)	---	Prevents from adjusting Vout below limit. Does not apply in analog programming. Preset by front panel or communication port.														
6.Over temperature protection	---	Shuts down the output. Auto recovery by autostart mode.														
7.Output under voltage protection (UVP)	---	Prevents adjustment of Vout below limit. P.S output turns Off during under voltage condition. Reset by AC input recycle in autostart mode, by Power Switch, by OUTPUT button, by rear panel or by communication.														

**FRONT PANEL**

1.Control functions	---	Multiple options with 2 Encoders.
	---	Vout/Iout/Power Limit manual adjust.
	---	OVP/UVL/UVP manual adjust.
	---	Protection Functions - OVP, UVL, UVP, Foldback, OCL, ENA, ILC.
	---	Communication Functions - Selection of LAN, RS232, RS485, USB or Optional communication interface.
	---	Output ON/OFF. Front Panel Lock.
	---	Communication Functions - Selection of Baud Rate, Address, IP and communication language.
	---	Analog Control Functions - Selection Voltage/resistive programming 5V/10V, 5KΩ/10KΩ programming.
2.Display	---	Vout: 4 digits, accuracy: 0.05% of rated output voltage +/-1 count.
	---	Iout: 4 digits, accuracy: 0.2% of rated output current +/-1 count.
3.Front Panel Buttons Indications	---	OUTPUT ON, ALARM, PREVIEW, FINE, COMMUNICATION, PROTECTION, CONFIGURATION, SYSTEM, SEQUENCER.
4.Front Panel Display Indications	---	Voltage, Current, Power, CV, CC, CP, External Voltage, External Current, Address, LFP Autostart, Safetstart, Foldback V/I, Remote (communication), RS/USB/LAN/Optional communication interface, Trigger, Load/Store Cell.
5.Circuit breaker	---	The AC supply for the Power System unit is protected by 2x80A circuit breakers for 200Vac & 2x40A circuit breakers for 380Vac. The CB's are accessible on the front panel of the cabinet.

**ENVIRONMENTAL CONDITIONS**

1.Operating temperature (*3)	---	0~50°C, 100% load.
2.Storage temperature	---	-25~65°C.
3.Operating humidity	---	20~90% RH (no condensation).
4.Storage humidity	---	10~95% RH (no condensation).
5.Altitude (*14)	---	Operating: 10000ft (3000m), output current derating 2%/100m or Ta derating 1°C/100m above 2000m. Non-operating: 40000ft (12000m).

## Mechanical

1.Cooling	---	Forced air cooling by power supply internal fans. Airflow direction: From cabinet front panel to rear.
2.Weight	Kg	Less than 153Kg.
3.Dimensions (WxHxD)	mm	W: 553, H: 1028 (With Castors; Without castors cabinet height is 947), D: 902.
4.Vibration (Package transportation)	---	ISTA 1H: 2014, Method: ASTM D4728 Random vibration test.
5.Shock & Drop (Package transportation)	---	ISTA 1H: 2014, Drop test Method: ASTM D5276 free fall; Rotation edge drop test: ASTM D6179 Rotational drop.

## SAFETY/EMC

1.Safety standards	---	IEC 61010-1:2010, EN 61010-1:2010
1.1.Interface classification	---	Vout≤50V Models: Output, J1, J2, J3, J4, J5, J6, J7, J8 (sense) and J9 (communication options) are Non Hazardous. 60≤Vout≤600V Models: Output and J8 (sense) are Hazardous. J1, J2, J3, J4, J5, J6, J7 and J9 (communication options) are Non Hazardous.
1.2.Withstand voltage	---	Vout≤50V Models: Input – Output & J8 (sense), J1, J2, J3, J4, J5, J6, J7 & J9 (communication options): 4242VDC 1min. Input – Ground: 2835VDC 1min. 60V≤Vout≤100V Models: Input – Output & J8 (sense), J1, J2, J3, J4, J5, J6, J7 & J9 (communication options): 4242VDC 1min. Output & J8 (sense) – J1, J2, J3, J4, J5, J6, J7 & J9 (communication options): 850VDC 1min. Output & J8 (sense) – Ground: 1500VDC 1min. Input – Ground: 2835VDC 1min. 100V<Vout≤600V Models: Input – Output & J8 (sense), J1, J2, J3, J4, J5, J6, J7 & J9 (communication options): 4242VDC 1min. Output & J8 (sense) – J1, J2, J3, J4, J5, J6, J7 & J9 (communication options): 1275VDC 1min. Output & J8 (sense) – Ground: 2500VDC 1min. Input – Ground: 2835VDC 1min.
2.EMC standards (*15) (*18)	---	IEC/EN61204-3 Industrial environment
2.1.Conducted emission (*18)	---	IEC/EN61204-3 Industrial environment, Annex H table H.1, FCC Part 15-A, VCCI-A.
2.2.Radiated emission (*18)	---	IEC/EN61204-3 Industrial environment, Annex H table H.3 and H.4, FCC Part 15-A, VCCI-A.

## REVISION:

IA979-01-03A

## NOTES:

- \*1: Minimum voltage is guaranteed to maximum 0.1% of rated output voltage.
- \*2: Minimum current is guaranteed to maximum 0.2% of rated output current.
- \*3: Model: 10V – Max. ambient temperature is 30°C. Output current derate 30A / 1°C
- \*4: For cases where conformance to various safety standards (IEC, etc...) is required, to be described as 190-240Vac (50/60Hz) for 3-Phase 200V models and 380-480Vac (50/60Hz) for 3-Phase 480V models.
- \*5: 3-Phase 200V models: At 200Vac input voltage, 3-Phase 480V: At 380Vac input voltage. With rated output power.
- \*6: 3-Phase 200V models: 170~265Vac, 3-Phase 480V models: 342~528Vac. Constant load.
- \*7: From No-Load to Full-Load, constant input voltage. Measured at the sensing point in Remote Sense.
- \*8: The maximum voltage on the power system terminals must not exceed the rated voltage.
- \*9: From 10% to 90% of Rated Output Voltage at rated resistive load.
- \*10: From 90% to 10% of Rated Output Voltage.
- \*11: For load voltage change, equal to the unit voltage rating, constant input voltage.
- \*12: The Constant Current programming, readback and monitoring accuracy do not include the warm-up and Load regulation thermal drift.
- \*13: Measured at the sensing point.
- \*14: For 10V model, Ta derating 2°C/100m.
- \*15: Signal and control ports interface cables length: Less than 3m, DC output power port cables length: Less than 30m.
- \*16: Max. ambient temperature for IEEE is 40C.
- \*17: For 10V model only: Max. output current for IEEE is 2700A up to 40C
- \*18: EMC specs based on GSP 15kW single unit.
- \*19: For steady state only.

## 5.2 45kW Series Specifications

Unless otherwise noted, specifications are warranted over the ambient temperature range of 0° to 50° Celsius.

OUTPUT RATING		20-2250	30-1530	40-1125	50-900	60-765	80-585	100-450	150-306	200-225	300-153	400-117	500-90	600-76.5
1. Rated output voltage (*1)	V	20	30	40	50	60	80	100	150	200	300	400	500	600
2. Rated output current (*2)	A	2250	1530	1125	900	765	585	450	306	225	153	117	90	76.5
3. Rated output power	W	45000	45900	45000	45000	45900	46800	45000	45900	45000	45900	46800	45000	45900

INPUT CHARACTERISTICS		V	20	30	40	50	60	80	100	150	200	300	400	500	600	
1. Input voltage/freq. 3 phase, 3 wire+ground (*3)	---	3-Phase, 200V models: 170~265Vac, 47~63Hz (Covers 200/230Vac).														
	---	3-Phase, 480V models: 342~528Vac, 47~63Hz (Covers 380/400/415/440/460/480Vac).														
2. Maximum Input current at 100% load	3-Phase, 200V models:	---	160A @ 200Vac.													
	3-Phase, 480V models:	---	84.3A @ 380Vac.													
3. Power Factor (Typ.)	---	0.94 @ 200/380Vac, rated output power.														
4. Efficiency (minimum) (*4)	%	87	88	89	90											

CONSTANT VOLTAGE MODE		V	20	30	40	50	60	80	100	150	200	300	400	500	600
1. Max. Line regulation (*5)	---	0.01% of rated output voltage.													
2. Max. Load regulation (*6)	---	0.01% of rated output voltage +5mV.													
3. Temperature coefficient	---	50PPM/°C from rated output voltage, following 30 minutes warm-up.													
4. Temperature stability	---	0.01% of rated Vout over 8hrs. interval following 30 minutes warm-up. Constant line, load & temperature.													
5. Warm-up drift	---	Less than 0.05% of rated output voltage +2mV over 30 minutes following power on.													
6. Remote sense compensation/wire (*7)	V	2	5	5	5	5	5	5	5	5	5	5	5	5	5
7. Up-prog. response time (*8)	mS	30	30	30	50	50	50	50	50	50	50	50	100	100	100
8. Down-prog. response time	Full load (*9)	mS	50	80	80	80	80	100	100	100	100	100	150	200	200
	No load (*9)	mS	600	800	900	950	1000	1200	1900	2000	2500	3000	4000	4000	3000
9. Transient response time	---	Time for output voltage to recover within 0.5% of its rated output for a load change 10~90% of rated output current. Output set point: 10~100%, Local sense. Less than 1mS for models up to and including 100V. 2mS for models above 100V.													

CONSTANT CURRENT MODE		V	20	30	40	50	60	80	100	150	200	300	400	500	600
1. Max. Line regulation (*5)	---	0.05% of rated output current.													
2. Max. Load regulation (*10)	---	0.08% of rated output current.													
3. Temperature coefficient	---	20V~100V models: 100PPM/°C from rated output current, following 30 minutes warm-up.													
	---	150V~600V models: 70PPM/°C from rated output current, following 30 minutes warm-up.													
4. Temperature stability	---	0.01% of rated Iout over 8hrs. interval following 30 minutes warm-up. Constant line, load & temperature.													
5. Warm-up drift	---	20V~100V models: Less than +/-0.25% of rated output current over 30 minutes following power on.													
	---	150V~600V models: Less than +/-0.15% of rated output current over 30 minutes following power on.													

ANALOG PROGRAMMING AND MONITORING (ISOLATED FROM THE OUTPUT)		---														
1. Vout voltage programming	---	0~100%, 0~5V or 0~10V, user selectable. Accuracy and linearity: +/-0.15% of rated Vout.														
2. Iout voltage programming (*11)	---	0~100%, 0~5V or 0~10V, user selectable. Accuracy and linearity: +/-0.4% of rated Iout.														
3. Vout resistor programming	---	0~100%, 0~5/10KΩ full scale, user selectable. Accuracy and linearity: +/-0.5% of rated Vout.														
4. Iout resistor programming (*11)	---	0~100%, 0~5/10KΩ full scale, user selectable. Accuracy and linearity: +/-0.5% of rated Iout.														
5. Output voltage monitor (*16)	---	0~5V or 0~10V, user selectable. Accuracy: +/-0.5% of rated Vout.														
6. Output current monitor (*11) (*16)	---	0~5V or 0~10V, user selectable. Accuracy: +/-0.5% of rated Iout.														

SIGNALS AND CONTROLS (ISOLATED FROM THE OUTPUT)		---														
1. Power supply OK #1 signal	---	Power supply output monitor. Open collector. Output On: On. Output Off: Off. Maximum Voltage: 30V. Maximum Sink Current: 10mA.														
2. CV/CC signal	---	CV/CC Monitor. Open collector. CC mode: On. CV mode: Off. Maximum Voltage: 30V. Maximum Sink Current: 10mA.														
3. LOCAL/REMOTE Analog control	---	Enable/Disable analog programming control by electrical signal or dry contact. Remote: 0~0.6V or short. Local: 2~30V or open.														
4. LOCAL/REMOTE Analog signal	---	Analog programming control monitor signal. Open collector. Remote: On. Local: Off. Maximum Voltage: 30V. Maximum Sink Current: 10mA.														
5. ENABLE/DISABLE signal	---	Enable/Disable PS output by electrical signal or dry contact. 0~0.6V or short, 2~30V or open. User selectable logic.														
6. INTERLOCK (ILC) control	---	Enable/Disable PS output by electrical signal or dry contact. Output ON: 0~0.6V or short. Output OFF: 2~30V or open.														
7. Programmed signals	---	Two open drain programmable signals. Maximum voltage 25V. Maximum sink current 100mA (shunted by 27V zener).														
8. TRIGGER IN / TRIGGER OUT signals	---	Maximum low level input voltage = 0.8V. Minimum high level input voltage = 2.5V. Maximum high level input = 5V positive edge trigger: tw = 10us minimum. Tr, Tf = 1us maximum. Min delay between 2 pulses 1ms.														
9. DAISY IN/SO control signal	---	By electrical Voltage: 0~0.6V/2~30V or dry contact.														
10. DAISY OUT/PS OK #2 signal	---	4~5V = OK, 0V (500Ω impedance) = Fail.														

## FUNCTIONS AND FEATURES

1.Parallel operation	---	Consult with Manufacturer.
2.Constant power control	---	Limits the output power to a programmed value. Programming via the communication ports or the front panel.
3.Output resistance control	---	Emulates series resistance. Resistance range: 1 ~ 1000mΩ. Programming via the communication ports or the front panel.
4.Slew rate control	---	Programmable Output rise and Output fall slew rate. Programming range: 0.0001~999.99V/mS or A/mS. Programming via communication ports or front panel.
5.Arbitrary waveforms	---	Profiles of upto 100 steps can be stored in 4 memory cells. Activation by command via communication ports or front panel.

## PROGRAMMING AND READBACK (USB, LAN, RS232/485, Optional (\*13) (\*14) Interfaces)

V	20	30	40	50	60	80	100	150	200	300	400	500	600	
1.Vout programming accuracy (*12)	---	0.05% of rated output voltage.												
2.Iout programming accuracy (*11)	---	0.3% of rated output current.												
3.Vout programming resolution	---	0.002% of rated output voltage.												
4.Iout programming resolution	---	0.002% of rated output current.												
5.Vout readback accuracy	---	0.05% of rated output voltage.												
6.Iout readback accuracy (*11)	---	0.2% of rated output current.												
7.Vout readback resolution	% of rated output voltage	0.006%	0.004%	0.003%	0.003%	0.002%	0.002%	0.011%	0.007%	0.005%	0.004%	0.003%	0.003%	0.002%
8.Iout readback resolution	% of rated output current	0.005%	0.007%	0.009%	0.0012%	0.002%	0.002%	0.003%	0.004%	0.005%	0.007%	0.009%	0.0012%	0.0014%

## PROTECTIVE FUNCTIONS

V	20	30	40	50	60	80	100	150	200	300	400	500	600	
1.Foldback protection	---	Output shut-down when power supply changes mode from CV or Power Limit to CC mode or from CC or Power Limit to CV mode. User presetable. Reset by AC input recycle in autostart mode, by Power Switch, by OUTPUT button, by rear panel or by communication.												
2.Over-voltage protection (OVP)	---	Output shut-down. Reset by AC input recycle in autostart mode, by Power Switch, by OUTPUT button, by rear panel or by communication.												
3.Over-voltage programming range	V	1~24	2~36	2~44.1	5~55.125	5~66.15	5~88.2	5~110.25	5~165.37	5~220.5	5~330.75	5~441	5~551.25	5~661.5
4.Over-voltage programming accuracy	---	+/-1% of rated output voltage.												
5.Output under voltage limit (UVL)	---	Prevents from adjusting Vout below limit. Does not apply in analog programming. Preset by front panel or communication port.												
6.Over temperature protection	---	Shuts down the output. Auto recovery by autostart mode.												
7.Output under voltage protection (UVP)	---	Prevents adjustment of Vout below limit. P.S output turns Off during under voltage condition. Reset by AC input recycle in autostart mode, by Power Switch, by OUTPUT button, by rear panel or by communication.												

## FRONT PANEL

1.Control functions	---	Multiple options with 2 Encoders.
	---	Vout/Iout/Power Limit manual adjust.
	---	OVP/UVL/UVP manual adjust.
	---	Protection Functions - OVP, UVL, UVP, Foldback, OCL, ENA, ILC.
	---	Communication Functions - Selection of LAN, RS232, RS485, USB or Optional communication interface.
	---	Output ON/OFF. Front Panel Lock.
	---	Communication Functions - Selection of Baud Rate, Address, IP and communication language.
	---	Analog Control Functions - Selection Voltage/resistive programming 5V/10V, 5KΩ/10KΩ programming.
2.Display	---	Analog Monitor Functions - Selection of Voltage/Current Monitoring 5V/10V.
	---	Vout: 4 digits, accuracy: 0.05% of rated output voltage +/-1 count. Iout: 4 digits, accuracy: 0.2% of rated output current +/-1 count.
3.Front Panel Buttons Indications	---	OUTPUT ON, ALARM, PREVIEW, FINE, COMMUNICATION, PROTECTION, CONFIGURATION, SYSTEM, SEQUENCER.
4.Front Panel Display Indications	---	Voltage, Current, Power, CV, CC, CP, External Voltage, External Current, Address, LFP Autostart, Safetstart, Foldback V/I, Remote (communication), RS/USB/LAN/Optional communication interface, Trigger, Load/Store Cell.
5.Circuit breaker	---	The AC supply for the Power System unit is protected by 3x80A circuit breakers for 200Vac input & 1x40A + 1x80A circuit breakers for 380Vac input. The CB's are accessible on the front panel of the cabinet.

## ENVIRONMENTAL CONDITIONS

1.Operating temperature	---	0~50°C, 100% load.
2.Storage temperature	---	-25~65°C.
3.Operating humidity	---	20~90% RH (no condensation).
4.Storage humidity	---	10~95% RH (no condensation).
5.Altitude	---	Operating: 10000ft (3000m), output current derating 2%/100m or Ta derating 1°C/100m above 2000m. Non-operating: 40000ft (12000m).

**MECHANICAL**

1.Cooling	---	Forced air cooling by power supply internal fans. Airflow direction: From cabinet front panel to rear.
2.Weight	Kg	Less than 177Kg.
3.Dimensions (WxHxD)	mm	W: 553, H: 1028 (With Castors; Without castors cabinet height is 947), D: 902.
4.Vibration (Package transportation)	---	ISTA 1H: 2014, Method: ASTM D4728 Random vibration test.
5.Shock & Drop (Package transportation)	---	ISTA 1H: 2014, Drop test Method: ASTM D5276 free fall; Rotation edge drop test: ASTM D6179 Rotational drop.

**SAFETY/EMC**

1.Safety standards	---	IEC 61010-1:2010, EN 61010-1:2010
1.1.Interface classification	---	Vouts<50V Models: Output, J1, J2, J3, J4, J5, J6, J7, J8 (sense) and J9 (communication options) are Non Hazardous. 60<Vouts<600V Models: Output and J8 (sense) are Hazardous. J1, J2, J3, J4, J5, J6, J7 and J9 (communication options) are Non Hazardous.
1.2.Withstand voltage	---	Vouts<50V Models: Input – Output & J8 (sense), J1, J2, J3, J4, J5, J6, J7 & J9 (communication options): 4242VDC 1min. Input – Ground: 2835VDC 1min. 60V<Vouts<100V Models: Input – Output & J8 (sense), J1, J2, J3, J4, J5, J6, J7 & J9 (communication options): 4242VDC 1min. Output & J8 (sense) – J1, J2, J3, J4, J5, J6, J7 & J9 (communication options): 850VDC 1min. Output & J8 (sense) – Ground: 1500VDC 1min. Input – Ground: 2835VDC 1min. 100V<Vouts<600V Models: Input – Output & J8 (sense), J1, J2, J3, J4, J5, J6, J7 & J9 (communication options): 4242VDC 1min. Output & J8 (sense) – J1, J2, J3, J4, J5, J6, J7 & J9 (communication options): 1275VDC 1min. Output & J8 (sense) – Ground: 2500VDC 1min. Input – Ground: 2835VDC 1min.
2.EMC standards (*13) (*15)	---	IEC/EN61204-3 Industrial environment
2.1.Conducted emission (*15)	---	IEC/EN61204-3 Industrial environment, Annex H table H.1, FCC Part 15-A, VCCI-A.
2.2.Radiated emission (*15)	---	IEC/EN61204-3 Industrial environment, Annex H table H.3 and H.4, FCC Part 15-A, VCCI-A.

**REVISION:**

**IA979-01-02A**

**NOTES:**

- \*1: Minimum voltage is guaranteed to maximum 0.1% of rated output voltage.
- \*2: Minimum current is guaranteed to maximum 0.2% of rated output current.
- \*3: For cases where conformance to various safety standards (IEC, etc...) is required, to be described as 190-240Vac (50/60Hz) for 3-Phase 200V models and 380-480Vac (50/60Hz) for 3-Phase 480V models.
- \*4: 3-Phase 200V models: At 200Vac input voltage, 3-Phase 480V: At 380Vac input voltage. With rated output power.
- \*5: 3-Phase 200V models: 170~265Vac, 3-Phase 480V models: 342~528Vac. Constant load.
- \*6: From No-Load to Full-Load, constant input voltage. Measured at the sensing point in Remote Sense.
- \*7: The maximum voltage on the power system terminals must not exceed the rated voltage.
- \*8: From 10% to 90% of Rated Output Voltage at rated resistive load.
- \*9: From 90% to 10% of Rated Output Voltage.
- \*10: For load voltage change, equal to the unit voltage rating, constant input voltage.
- \*11: The Constant Current programming, readback and monitoring accuracy do not include the warm-up and Load regulation thermal drift.
- \*12: Measured at the sensing point.
- \*13: Signal and control ports interface cables length: Less than 3m, DC output power port cables length: Less than 30m.
- \*14: Max. ambient temperature for IEEE is 40C.
- \*15: EMC specs based on GSP15kW series.
- \*16: For steady state only.

## 5.3 45kW: 1000V and 1500V Series Specifications

Unless otherwise noted, specifications are warranted over the ambient temperature range of 0° to 50° Celsius.

OUTPUT RATING		1000-45	1500-30
1. Rated output voltage (*1)	V	1000	1500
2. Rated output current (*2)	A	45	30
3. Rated output power	W	45000	45000

INPUT CHARACTERISTICS		V	1000	1500
1. Input voltage/freq, 3 phase, 3 wire+ground (*4)	---	---	3-Phase, 480V models: 342~528Vac, 47~63Hz (Covers 380/400/415/440/460/480Vac).	
2. Maximum Input current at 100% load	3-Phase, 480V models:	---	81A @ 380Vac.	
3. Power Factor (Typ.)	---	---	0.94 @ 380Vac, rated output power.	
4. Efficiency (Minimum) (*3) (*5)	%	---	90	

CONSTANT VOLTAGE MODE		V	1000	1500
1. Max. Line regulation (*6)	---	---	0.01% of rated output voltage.	
2. Max. Load regulation (*7)	---	---	0.01% of rated output voltage +5mV.	
3. Temperature coefficient	---	---	50PPM/°C from rated output voltage, following 30 minutes warm-up.	
4. Temperature stability	---	---	0.01% of rated Vout over 8hrs. interval following 30 minutes warm-up. Constant line, load & temperature.	
5. Warm-up drift	---	---	Less than 0.05% of rated output voltage +2mV over 30 minutes following power on.	
6. Remote sense compensation/wire (*8)	V	---	5	
7. Up-prog. response time (*9)	mS	---	150	200
8. Down-prog. response time	Full load (*10)	mS	100	100
	No load (*10)	mS	3000	3000
9. Transient response time	---	---	Time for output voltage to recover within 0.5% of its rated output, for a load change 10~90% of rated output current Local sense. Output set point: 10~100%. Less than 2mS.	

CONSTANT CURRENT MODE		V	1000	1500
1. Max. Line regulation (*6)	---	---	0.05% of rated output current.	
2. Max. Load regulation (*11)	---	---	0.08% of rated output current.	
3. Temperature coefficient	---	---	70PPM/°C from rated output current, following 30 minutes warm-up.	
4. Temperature stability	---	---	0.01% of rated Iout over 8hrs. interval following 30 minutes warm-up. Constant line, load & temperature.	
5. Warm-up drift	---	---	Less than +/-0.15% of rated output current over 30 minutes following power on.	

### ANALOG PROGRAMMING AND MONITORING (ISOLATED FROM THE OUTPUT)

1. Vout voltage programming	---	0~100%, 0~5V or 0~10V, user selectable. Accuracy and linearity: +/-0.15% of rated Vout.
2. Iout voltage programming (*13)	---	0~100%, 0~5V or 0~10V, user selectable. Accuracy and linearity: +/-0.4% of rated Iout.
3. Vout resistor programming	---	0~100%, 0~5/10KΩ full scale, user selectable. Accuracy and linearity: +/-0.5% of rated Vout.
4. Iout resistor programming (*13)	---	0~100%, 0~5/10KΩ full scale, user selectable. Accuracy and linearity: +/-0.5% of rated Iout.
5. Output voltage monitor (*12)	---	0~5V or 0~10V, user selectable. Accuracy: +/-0.5% of rated Vout.
6. Output current monitor (*12) (*13)	---	0~5V or 0~10V, user selectable. Accuracy: +/-0.5% of rated Iout.

### SIGNALS AND CONTROLS (ISOLATED FROM THE OUTPUT)

1. Power supply OK #1 signal	---	Power supply output monitor. Open collector. Output On: On. Output Off: Off. Maximum Voltage: 30V. Maximum Sink Current: 10mA.
2. CV/CC signal	---	CV/CC Monitor. Open collector. CC mode: On. CV mode: Off. Maximum Voltage: 30V. Maximum Sink Current: 10mA.
3. LOCAL/REMOTE Analog control	---	Enable/Disable analog programming control by electrical signal or dry contact. Remote: 0~0.6V or short. Local: 2~30V or open.
4. LOCAL/REMOTE Analog signal	---	Analog programming control monitor signal. Open collector. Remote: On. Local: Off. Maximum Voltage: 30V. Maximum Sink Current: 10mA.
5. ENABLE/DISABLE signal	---	Enable/Disable PS output by electrical signal or dry contact. 0~0.6V or short, 2~30V or open. User selectable logic.
6. INTERLOCK (ILC) control	---	Enable/Disable PS output by electrical signal or dry contact. Output ON: 0~0.6V or short. Output OFF: 2~30V or open.
7. Programmed signals	---	Two open drain programmable signals. Maximum voltage 25V. Maximum sink current 100mA (shunted by 27V zener).
8. TRIGGER IN / TRIGGER OUT signals	---	Maximum low level input voltage = 0.8V. Minimum high level input voltage = 2.5V. Maximum high level input = 5V positive edge trigger: tw = 10uS minimum. Tr, Tf = 1uS maximum. Min delay between 2 pulses 1mS.
9. DAISY_IN/SO control signal	---	By electrical Voltage: 0~0.6V/2~30V or dry contact.
10. DAISY_OUT/PS_OK #2 signal	---	4~5V = OK, 0V (500Ω impedance) = Fail.

### FUNCTIONS AND FEATURES

1. Parallel operation	---	Consult with manufacturer.
2. Constant power control	---	Limits the output power to a programmed value. Programming via the communication ports or the front panel.
3. Output resistance control	---	Emulates series resistance. Resistance range: 1~1000mΩ. Programming via communication ports or front panel.
4. Slew rate control	---	Programmable Output rise and Output fall slew rate. Programming range: 0.0001~999.99 V/mS. or A/mS. Programming via communication ports or front panel.
5. Arbitrary waveforms	---	Profiles of up to 100 steps can be stored in 4 memory cells. Activation by command via communication ports or front panel.

**PROGRAMMING AND READBACK (USB, LAN, RS232/485, Optional (\*15) (\*16) Interfaces)**

	V	1000	1500
1.Vout programming accuracy (*14)	---	0.05% of rated output voltage.	
2.Iout programming accuracy (*13)	---	0.3% of rated output current.	
3.Vout programming resolution	---	0.002% of rated output voltage.	
4.Iout programming resolution	---	0.002% of rated output current.	
5.Vout readback accuracy	---	0.1% of rated output voltage.	
6.Iout readback accuracy (*13)	---	0.2% of rated output current.	
7.Vout readback resolution	% of rated output voltage	0.008%	0.008%
8.Iout readback resolution	% of rated output current	0.002%	0.002%

**PROTECTIVE FUNCTIONS**

	V	1000	1500
1.Foldback protection	---	Output shut-down when power supply changes mode from CV or Power Limit to CC mode or from CC or Power Limit to CV mode. User presetable. Reset by AC input recycle in autostart mode, by Power Switch, by OUTPUT button, by rear panel or by communication.	
2.Over-voltage protection (OVP)	---	Output shut-down. Reset by AC input recycle in autostart mode, by Power Switch, by OUTPUT button, by rear panel or by communication.	
3.Over-voltage programming range	V	5~1102.5	5~1653.75
4.Over-voltage programming accuracy	---	+/-1% of rated output voltage.	
5.Output under voltage limit (UVL)	---	Prevents from adjusting Vout below limit. Does not apply in analog programming. Preset by front panel or communication port.	
6.Over temperature protection	---	Shuts down the output. Auto recovery by autostart mode.	
7.Output under voltage protection (UVP)	---	Prevents adjustment of Vout below limit. P.S output turns Off during under voltage condition. Reset by AC input recycle in autostart mode, by Power Switch, by OUTPUT button, by rear panel or by communication.	

**FRONT PANEL**

1.Control functions	---	Multiple options with 2 Encoders.
	---	Vout/Iout/Power Limit manual adjust.
	---	OVP/UVL/UVP manual adjust.
	---	Protection Functions - OVP, UVL, UVP, Foldback, OCL, ENA, ILC.
	---	Communication Functions - Selection of LAN, RS232, RS485, USB or Optional communication interface.
	---	Output ON/OFF. Front Panel Lock.
	---	Communication Functions - Selection of Baud Rate, Address, IP and communication language.
	---	Analog Control Functions - Selection Voltage/resistive programming 5V/10V, 5KΩ/10KΩ programming.
2.Display	---	Vout: 4 digits, accuracy: 0.05% of rated output voltage +/- 1 count.
	---	Iout: 4 digits, accuracy: 0.2% of rated output current +/- 1 count.
3.Front Panel Buttons Indications	---	OUTPUT ON, ALARM, PREVIEW, FINE, COMMUNICATION, PROTECTION, CONFIGURATION, SYSTEM, SEQUENCER.
4.Front Panel Display Indications	---	Voltage, Current, Power, CV, CC, CP, External Voltage, External Current, Address, LFP Autostart, Safetstart, Foldback V/I, Remote (communication), RS/USB/LAN/Optional communication interface, Trigger, Load/Store Cell.
5.Circuit breaker	---	The AC supply for the Power System unit is protected by 2 x 80A circuit breakers. These CB's are accessible on the front panel of the cabinet.

**ENVIRONMENTAL CONDITIONS**

1.Operating temperature	---	0~50°C, 100% load.
2.Storage temperature	---	-25~65°C.
3.Operating humidity	---	20~90% RH (no condensation).
4.Storage humidity	---	10~95% RH (no condensation).
5.Altitude(*15)	---	Operating: 10000ft (3000m), output current derating 2%/100m or Ta derating 1°C/100m above 2000m. Non-operating: 40000ft (12000m).

**MECHANICAL**

1.Cooling	---	Forced air cooling by power supply internal fans. Airflow direction: From cabinet front panel to rear.
2.Weight	Kg	Less than 155.
3.Dimensions (WxHxD)	mm	W: 553, H: 1028 (With Castors; Without castors cabinet height is 947), D: 902.
4.Vibration (Package transportation)	---	ISTA 1H: 2014, Method: ASTM D4728 Random vibration test.
5.Shock & Drop (Package transportation)	---	ISTA 1H: 2014, Drop test Method: ASTM D5276 free fall; Rotation edge drop test: ASTM D6179 Rotational drop.

**SAFETY/EMC**

1.Safety standards	---	IEC 61010-1:2010, EN 61010-1:2010
1.1.Interface classification	---	Output & J8 (sense) are hazardous, J1, J2, J3, J4, J5, J6, J7 & J9 (communication options) are Non Hazardous.
1.2.Withstand voltage	---	Input - Output & J8 (sense), J1, J2, J3, J4, J5, J6, J7 and J9 (communication options): 4000VDC 1min, Output & J8 (sense) - J1, J2, J3, J4, J5, J6, J7 & J9 (communication options): 2250 1min, Output & J8 (sense) - Ground: 3280VDC 1min. Input - Ground: 2835VDC 1min.
2.EMC standards (*16) (*17)	---	IEC/EN61204-3 Industrial environment.
2.1.Conducted emission (*17)	---	IEC/EN61204-3 Industrial environment, Annex H table H.1, FCC Part 15-A, VCCI-A.
2.2.Radiated emission (*17)	---	IEC/EN61204-3 Industrial environment, Annex H table H.3 and H.4, FCC Part 15-A, VCCI-A.

REVISION:  
IA1038-01-03A

**NOTES:**

- \*1: Minimum voltage is guaranteed to maximum 0.1% of rated output voltage.
- \*2: Minimum current is guaranteed to maximum 0.2% of rated output current.
- \*3: Typ. at Ta=25°C, rated output power.
- \*4: For cases where conformance to various safety standards (UL, IEC, etc...) is required, to be described as 380~480Vac (50/60Hz) for 3-Phase 480V models.
- \*5: 3-Phase 480V: At 380Vac input voltage. With rated output power.
- \*6: 3-Phase 480V models: 342~528Vac. Constant load.
- \*7: From No-Load to Full-Load, constant input voltage. Measured at the sensing point in Remote Sense.
- \*8: The maximum voltage on the power supply terminals must not exceed the rated voltage.
- \*9: From 10% to 90% of Rated Output Voltage at rated resistive load.
- \*10: From 90% to 10% of Rated Output Voltage.
- \*11: For load voltage change, equal to the unit voltage rating, constant input voltage.
- \*12: For steady state only.
- \*13: The Constant Current programming, readback and monitoring accuracy do not include the warm-up and Load regulation thermal drift.
- \*14: Measured at the sensing point.
- \*15: Max. ambient temperature for IEEE is 40°C.
- \*16: Signal and control ports interface cables length: Less than 3m, DC output power port cables length: Less than 30m.
- \*17: EMC specs based on GSPL22.5kW series.

## 5.4 60kW Series Specifications

Unless otherwise noted, specifications are warranted over the ambient temperature range of 0° to 50° Celsius.

OUTPUT RATING		10-4500	20-3000	30-2040	40-1500	50-1200	60-1020	80-780	100-600	150-408	200-300	300-204	400-156	500-120	600-102
1. Rated output voltage (*1)	V	10	20	30	40	50	60	80	100	150	200	300	400	500	600
2. Rated output current (*2)	A	4500 (*3)	3000	2040	1500	1200	1020	780	600	408	300	204	156	120	102
3. Rated output power	W	45000	60000	61200	60000	60000	61200	62400	60000	61200	60000	61200	62400	60000	61200

INPUT CHARACTERISTICS		V	10	20	30	40	50	60	80	100	150	200	300	400	500	600
1. Input voltage/freq. 3 phase, 3 wire+ground (*4)		---	3-Phase, 200V models: 170~265Vac, 47~63Hz (Covers 200/230Vac). 3-Phase, 480V models: 342~528Vac, 47~63Hz (Covers 380/400/415/440/460/480Vac).													
2. Maximum Input current at 100% load	3-Phase, 200V models: 3-Phase, 480V models:	---	212A @ 200Vac. 110.4A @ 380Vac.													
3. Power Factor (Typ.)		---	0.94 @ 200/380Vac, rated output power.													
4. Efficiency (minimum) (*5)	%		87	88	89							90				

CONSTANT VOLTAGE MODE		V	10	20	30	40	50	60	80	100	150	200	300	400	500	600	
1. Max. Line regulation (*6)		---	0.01% of rated output voltage.														
2. Max. Load regulation (*7)		---	0.01% of rated output voltage +5mV.														
3. Temperature coefficient		---	50PPM/°C from rated output voltage, following 30 minutes warm-up.														
4. Temperature stability		---	0.01% of rated Vout over 8hrs. interval following 30 minutes warm-up. Constant line, load & temperature.														
5. Warm-up drift		---	Less than 0.05% of rated output voltage +2mV over 30 minutes following power on.														
6. Remote sense compensation/wire (*8)	V	2	2	5	5	5	5	5	5	5	5	5	5	5	5	5	
7. Up-prog. response time (*9)	mS	30	30	30	30	50	50	50	50	50	50	50	50	100	100	100	
8. Down-prog. response time	Full load (*10)	mS	50	50	80	80	80	80	100	100	100	100	100	100	150	200	200
	No load (*10)	mS	300	600	800	900	950	1000	1200	1900	2000	2500	3000	4000	4000	3000	
9. Transient response time		---	Time for output voltage to recover within 0.5% of its rated output for a load change 10~90% of rated output current. Output set point: 10~100%, Local sense. Less than 1mS for models up to and including 100V. 2mS for models above 100V.														

CONSTANT CURRENT MODE		V	10	20	30	40	50	60	80	100	150	200	300	400	500	600
1. Max. Line regulation (*6)		---	0.05% of rated output current.													
2. Max. Load regulation (*11)		---	0.08% of rated output current.													
3. Temperature coefficient		---	10V~100V models: 100PPM/°C from rated output current, following 30 minutes warm-up. 150V~600V models: 70PPM/°C from rated output current, following 30 minutes warm-up.													
4. Temperature stability		---	0.01% of rated Iout over 8hrs. interval following 30 minutes warm-up. Constant line, load & temperature.													
5. Warm-up drift		---	10V~100V models: Less than +/-0.25% of rated output current over 30 minutes following power on. 150V~600V models: Less than +/-0.15% of rated output current over 30 minutes following power on.													

### ANALOG PROGRAMMING AND MONITORING (ISOLATED FROM THE OUTPUT)

1. Vout voltage programming	---	0~100%, 0~5V or 0~10V, user selectable. Accuracy and linearity: +/-0.15% of rated Vout.														
2. Iout voltage programming (*12)	---	0~100%, 0~5V or 0~10V, user selectable. Accuracy and linearity: +/-0.4% of rated Iout.														
3. Vout resistor programming	---	0~100%, 0~5/10KΩ full scale, user selectable. Accuracy and linearity: +/-0.5% of rated Vout.														
4. Iout resistor programming (*12)	---	0~100%, 0~5/10KΩ full scale, user selectable. Accuracy and linearity: +/-0.5% of rated Iout.														
5. Output voltage monitor (*19)	---	0~5V or 0~10V, user selectable. Accuracy: +/-0.5% of rated Vout.														
6. Output current monitor (*12) (*19)	---	0~5V or 0~10V, user selectable. Accuracy: +/-0.5% of rated Iout.														

### SIGNALS AND CONTROLS (ISOLATED FROM THE OUTPUT)

1. Power supply OK #1 signal	---	Power supply output monitor. Open collector. Output On: On. Output Off: Off. Maximum Voltage: 30V. Maximum Sink Current: 10mA.														
2. CV/CC signal	---	CV/CC Monitor. Open collector. CC mode: On. CV mode: Off. Maximum Voltage: 30V. Maximum Sink Current: 10mA.														
3. LOCAL/REMOTE Analog control	---	Enable/Disable analog programming control by electrical signal or dry contact. Remote: 0~0.6V or short. Local: 2~30V or open.														
4. LOCAL/REMOTE Analog signal	---	Analog programming control monitor signal. Open collector. Remote: On. Local: Off. Maximum Voltage: 30V. Maximum Sink Current: 10mA.														
5. ENABLE/DISABLE signal	---	Enable/Disable PS output by electrical signal or dry contact. 0~0.6V or short, 2~30V or open. User selectable logic.														
6. INTERLOCK (ILC) control	---	Enable/Disable PS output by electrical signal or dry contact. Output ON: 0~0.6V or short. Output OFF: 2~30V or open.														
7. Programmed signals	---	Two open drain programmable signals. Maximum voltage 25V. Maximum sink current 100mA (shunted by 27V zener).														
8. TRIGGER IN / TRIGGER OUT signals	---	Maximum low level input voltage = 0.8V. Minimum high level input voltage = 2.5V. Maximum high level input = 5V positive edge trigger. tw = 10us minimum. Tr, Tf = 1us maximum. Min delay between 2 pulses 1ms.														
9. DAISY_IN/SO control signal	---	By electrical Voltage: 0~0.6V/2~30V or dry contact.														
10. DAISY_OUT/PS_OK #2 signal	---	4~5V = OK, 0V (500Ω impedance) = Fail.														

## FUNCTIONS AND FEATURES

1.Parallel operation	---	Consult with manufacturer
2.Constant power control	---	Limits the output power to a programmed value. Programming via the communication ports or the front panel
3.Output resistance control	---	Emulates series resistance. Resistance range: 1~1000mΩ. Programming via the communication ports or the front panel.
4.Slew rate control	---	Programmable Output rise and Output fall slew rate. Programming range: 0.0001~999.99 V/mS, or A/mS. Programming via communication ports or front panel.
5.Arbitrary waveforms	---	Profiles of upto 100 steps can be stored in 4 memory cells. Activation by command via communication ports or front panel.

## PROGRAMMING AND READBACK (USB, LAN, RS232/485, Optional (\*15) (\*16) (\*17) Interfaces)

	V	10	20	30	40	50	60	80	100	150	200	300	400	500	600	
1.Vout programming accuracy (*13)	---	0.05% of rated output voltage.														
2.Iout programming accuracy (*12)	---	0.3% of rated output current.														
3.Vout programming resolution	---	0.002% of rated output voltage.														
4.Iout programming resolution	---	0.002% of rated output current.														
5.Vout readback accuracy	---	0.05% of rated output voltage.														
6.Iout readback accuracy (*12)	---	0.2% of rated output current.														
7.Vout readback resolution	% of rated output voltage	0.011%	0.006%	0.004%	0.003%	0.003%	0.002%	0.002%	0.011%	0.007%	0.005%	0.004%	0.003%	0.003%	0.002%	
8.Iout readback resolution	% of rated output current	0.003%	0.004%	0.005%	0.007%	0.01%	0.01%	0.0013%	0.002%	0.003%	0.004%	0.005%	0.007%	0.009%	0.01%	

## PROTECTIVE FUNCTIONS

	V	10	20	30	40	50	60	80	100	150	200	300	400	500	600	
1.Foldback protection	---	Output shut-down when power supply changes mode from CV or Power Limit to CC mode or from CC or Power Limit to CV mode. User presetable. Reset by AC input recycle in autostart mode, by Power Switch, by OUTPUT button, by rear panel or by communication.														
2.Over-voltage protection (OVP)	---	Output shut-down. Reset by AC input recycle in autostart mode, by Power Switch, by OUTPUT button, by rear panel or by communication.														
3.Over-voltage programming range	V	0.5~12	1~24	2~36	2~44.1	5~55.125	5~66.15	5~88.2	5~110.25	5~165.37	5~220.5	5~330.75	5~441	5~551.25	5~661.5	
4.Over-voltage programming accuracy	---	+/-1% of rated output voltage.														
5.Output under voltage limit (UVL)	---	Prevents from adjusting Vout below limit. Does not apply in analog programming. Preset by front panel or communication port.														
6.Over temperature protection	---	Shuts down the output. Auto recovery by autostart mode.														
7.Output under voltage protection (UVP)	---	Prevents adjustment of Vout below limit. P.S output turns Off during under voltage condition. Reset by AC input recycle in autostart mode, by Power Switch, by OUTPUT button, by rear panel or by communication.														

## FRONT PANEL

1.Control functions	---	Multiple options with 2 Encoders.
	---	Vout/Iout/Power Limit manual adjust.
	---	OVP/UVL/UVP manual adjust.
	---	Protection Functions - OVP, UVL, UVP, Foldback, OCL, ENA, ILC.
	---	Communication Functions - Selection of LAN, RS232, RS485, USB or Optional communication interface.
	---	Output ON/OFF. Front Panel Lock.
	---	Communication Functions - Selection of Baud Rate, Address, IP and communication language.
	---	Analog Control Functions - Selection Voltage/resistive programming 5V/10V, 5KΩ/10KΩ programming.
	---	Analog Monitor Functions - Selection of Voltage/Current Monitoring 5V/10V.
2.Display	---	Vout: 4 digits, accuracy: 0.05% of rated output voltage +/-1 count.
	---	Iout: 4 digits, accuracy: 0.2% of rated output current +/-1 count.
3.Front Panel Buttons Indications	---	OUTPUT ON, ALARM, PREVIEW, FINE, COMMUNICATION, PROTECTION, CONFIGURATION, SYSTEM, SEQUENCER.
4.Front Panel Display Indications	---	Voltage, Current, Power, CV, CC, CP, External Voltage, External Current, Address, LFP Autostart, Safetstart, Foldback V/I, Remote (communication), RS/USB/LAN/Optional communication interface, Trigger, Load/Store Cell.
5.Circuit breaker	---	The AC supply for the Power System unit is protected by 80A circuit breakers. These CB's are accessible on the front panel of the cabinet.

## ENVIRONMENTAL CONDITIONS

1.Operating temperature (*3)	---	0~50°C, 100% load.
2.Storage temperature	---	-25~65°C.
3.Operating humidity	---	20~90% RH (no condensation).
4.Storage humidity	---	10~95% RH (no condensation).
5.Altitude (*14)	---	Operating: 10000ft (3000m), output current derating 2%/100m or Ta derating 1°C/100m above 2000m. Non-operating: 40000ft (12000m).

**MECHANICAL**

1.Cooling	---	Forced air cooling by power supply internal fans. Airflow direction: From cabinet front panel to rear.
2.Weight	Kg	Less than 200Kg.
3.Dimensions (WxHxD)	mm	W: 553, H: 1028 (With Castors; Without castors cabinet height is 947), D: 902.
4.Vibration (Package Transportation)	---	ISTA 1H: 2014, Method: ASTM D4728 Random vibration test.
5.Shock & Drop (Package Transportation)	---	ISTA 1H: 2014, Drop test Method: ASTM D5276 free fall; Rotation edge drop test: ASTM D6179 Rotational drop.

**SAFETY/EMC**

1.Safety standards	---	IEC 61010-1:2010, EN 61010-1:2010
1.1.Interface classification	---	Vouts50V Models: Output, J1, J2, J3, J4, J5, J6, J7, J8 (sense) and J9 (communication options) are Non Hazardous. 60s<Vouts600V Models: Output and J8 (sense) are Hazardous. J1, J2, J3, J4, J5, J6, J7 and J9 (communication options) are Non Hazardous.
1.2.Withstand voltage	---	Vouts50V Models: Input – Output & J8 (sense), J1, J2, J3, J4, J5, J6, J7 & J9 (communication options): 4242VDC 1min. Input – Ground: 2835VDC 1min. 60V<Vouts100V Models: Input – Output & J8 (sense), J1, J2, J3, J4, J5, J6, J7 & J9 (communication options): 4242VDC 1min. Output & J8 (sense) – J1, J2, J3, J4, J5, J6, J7 & J9 (communication options): 850VDC 1min. Output & J8 (sense) – Ground: 1500VDC 1min. Input – Ground: 2835VDC 1min. 100V<Vouts600V Models: Input – Output & J8 (sense), J1, J2, J3, J4, J5, J6, J7 & J9 (communication options): 4242VDC 1min. Output & J8 (sense) – J1, J2, J3, J4, J5, J6, J7 & J9 (communication options): 1275VDC 1min. Output & J8 (sense) – Ground: 2500VDC 1min. Input – Ground: 2835VDC 1min.
2.EMC standards (*15) (*18)	---	IEC/EN61204-3 Industrial environment
2.1.Conducted emission (*18)	---	IEC/EN61204-3 Industrial environment, Annex H table H.1, FCC Part 15-A, VCCI-A.
2.2.Radiated emission (*18)	---	IEC/EN61204-3 Industrial environment, Annex H table H.3 and H.4, FCC Part 15-A, VCCI-A.

**REVISION:**

IA979-01-01A

**NOTES:**

- \*1: Minimum voltage is guaranteed to maximum 0.1% of rated output voltage.
- \*2: Minimum current is guaranteed to maximum 0.2% of rated output current.
- \*3: Model: 10V – Max. ambient temperature is 40°C.
- \*4: For cases where conformance to various safety standards (IEC, etc...) is required, to be described as 190-240Vac (50/60Hz) for 3-Phase 200V models and 380-480Vac (50/60Hz) for 3-Phase 480V models.
- \*5: 3-Phase 200V models: At 200Vac input voltage, 3-Phase 480V: At 380Vac input voltage. With rated output power.
- \*6: 3-Phase 200V models: 170~265Vac, 3-Phase 480V models: 342~528Vac. Constant load.
- \*7: From No-Load to Full-Load, constant input voltage. Measured at the sensing point in Remote Sense.
- \*8: The maximum voltage on the power system terminals must not exceed the rated voltage.
- \*9: From 10% to 90% of Rated Output Voltage at rated resistive load.
- \*10: From 90% to 10% of Rated Output Voltage.
- \*11: For load voltage change, equal to the unit voltage rating, constant input voltage.
- \*12: The Constant Current programming, readback and monitoring accuracy do not include the warm-up and Load regulation thermal drift.
- \*13: Measured at the sensing point.
- \*14: For 10V model, Ta derating 2°C/100m.
- \*15: Signal and control ports interface cables length: Less than 3m, DC output power port cables length: Less than 30m.
- \*16: Max. ambient temperature for IEEE is 40C.
- \*17: For 10V model only: Max. output current for IEEE is 4500A up to 40C
- \*18: EMC specs based on GSP15kW single unit.
- \*19: For steady state only.

# 5.5 67.5kW Series Specifications

Unless otherwise noted, specifications are warranted over the ambient temperature range of 0° to 50° Celsius.

OUTPUT RATING		1000-67.5	1500-45
1. Rated output voltage (*1)	V	1000	1500
2. Rated output current (*2)	A	67.5	45
3. Rated output power	W	67500	67500

INPUT CHARACTERISTICS		V	1000	1500
1. Input voltage/freq, 3 phase, 3 wire+ground (*4)	---	3-Phase, 480V models: 342~528Vac, 47~63Hz (Covers 380/400/415/440/460/480Vac).		
2. Maximum Input current at 100% load	3-Phase, 480V models:	---	121.5A @ 380Vac.	
3. Power Factor (Typ.)	---	0.94 @ 380Vac, rated output power.		
4. Efficiency (Minimum) (*3) (*5)	%	90		

CONSTANT VOLTAGE MODE		V	1000	1500
1. Max. Line regulation (*6)	---	0.01% of rated output voltage.		
2. Max. Load regulation (*7)	---	0.01% of rated output voltage +5mV.		
3. Temperature coefficient	---	50PPM/°C from rated output voltage, following 30 minutes warm-up.		
4. Temperature stability	---	0.01% of rated Vout over 8hrs. interval following 30 minutes warm-up. Constant line, load & temperature.		
5. Warm-up drift	---	Less than 0.05% of rated output voltage +2mV over 30 minutes following power on.		
6. Remote sense compensation/wire (*8)	V	5		
7. Up-prog. response time (*9)	mS	150	200	200
8. Down-prog. response time	Full load (*10)	100	100	100
	No load (*10)	3000	3000	3000
9. Transient response time	---	Time for output voltage to recover within 0.5% of its rated output, for a load change 10~90% of rated output current Local sense. Output set point: 10~100%. Less than 2mS.		

CONSTANT CURRENT MODE		V	1000	1500
1. Max. Line regulation (*6)	---	0.05% of rated output current.		
2. Max. Load regulation (*11)	---	0.08% of rated output current.		
3. Temperature coefficient	---	70PPM/°C from rated output current, following 30 minutes warm-up.		
4. Temperature stability	---	0.01% of rated Iout over 8hrs. interval following 30 minutes warm-up. Constant line, load & temperature.		
5. Warm-up drift	---	Less than +/-0.15% of rated output current over 30 minutes following power on.		

### ANALOG PROGRAMMING AND MONITORING (ISOLATED FROM THE OUTPUT)

1. Vout voltage programming	---	0~100%, 0~5V or 0~10V, user selectable. Accuracy and linearity: +/-0.15% of rated Vout.		
2. Iout voltage programming (*13)	---	0~100%, 0~5V or 0~10V, user selectable. Accuracy and linearity: +/-0.4% of rated Iout.		
3. Vout resistor programming	---	0~100%, 0~5/10KΩ full scale, user selectable. Accuracy and linearity: +/-0.5% of rated Vout.		
4. Iout resistor programming (*13)	---	0~100%, 0~5/10KΩ full scale, user selectable. Accuracy and linearity: +/-0.5% of rated Iout.		
5. Output voltage monitor (*12)	---	0~5V or 0~10V, user selectable. Accuracy: +/-0.5% of rated Vout.		
6. Output current monitor (*12) (*13)	---	0~5V or 0~10V, user selectable. Accuracy: +/-0.5% of rated Iout.		

### SIGNALS AND CONTROLS (ISOLATED FROM THE OUTPUT)

1. Power supply OK #1 signal	---	Power supply output monitor. Open collector. Output On: On. Output Off: Off. Maximum Voltage: 30V. Maximum Sink Current: 10mA.		
2. CV/CC signal	---	CV/CC Monitor. Open collector. CC mode: On. CV mode: Off. Maximum Voltage: 30V. Maximum Sink Current: 10mA.		
3. LOCAL/REMOTE Analog control	---	Enable/Disable analog programming control by electrical signal or dry contact. Remote: 0~0.6V or short. Local: 2~30V or open.		
4. LOCAL/REMOTE Analog signal	---	Analog programming control monitor signal. Open collector. Remote: On. Local: Off. Maximum Voltage: 30V. Maximum Sink Current: 10mA.		
5. ENABLE/DISABLE signal	---	Enable/Disable PS output by electrical signal or dry contact. 0~0.6V or short, 2~30V or open. User selectable logic.		
6. INTERLOCK (ILC) control	---	Enable/Disable PS output by electrical signal or dry contact. Output ON: 0~0.6V or short. Output OFF: 2~30V or open.		
7. Programmed signals	---	Two open drain programmable signals. Maximum voltage 25V. Maximum sink current 100mA (shunted by 27V zener).		
8. TRIGGER IN / TRIGGER OUT signals	---	Maximum low level input voltage = 0.8V. Minimum high level input voltage = 2.5V. Maximum high level input = 5V positive edge trigger: tw = 10uS minimum. Tr, Tf = 1uS maximum. Min delay between 2 pulses 1mS.		
9. DAISY_IN/SO control signal	---	By electrical Voltage: 0~0.6V/2~30V or dry contact.		
10. DAISY_OUT/PS_OK #2 signal	---	4~5V = OK, 0V (500Ω impedance) = Fail.		

### FUNCTIONS AND FEATURES

1. Parallel operation	---	Consult with manufacturer.		
2. Constant power control	---	Limits the output power to a programmed value. Programming via the communication ports or the front panel.		
3. Output resistance control	---	Emulates series resistance. Resistance range: 1~1000mΩ. Programming via communication ports or front panel.		
4. Slew rate control	---	Programmable Output rise and Output fall slew rate. Programming range: 0.0001~999.99 V/mS. or A/mS. Programming via communication ports or front panel.		
5. Arbitrary waveforms	---	Profiles of up to 100 steps can be stored in 4 memory cells. Activation by command via communication ports or front panel.		

**PROGRAMMING AND READBACK (USB, LAN, RS232/485, Optional (\*15) (\*16) Interfaces)**

	V	1000	1500
1.Vout programming accuracy (*14)	---	0.05% of rated output voltage.	
2.Iout programming accuracy (*13)	---	0.3% of rated output current.	
3.Vout programming resolution	---	0.002% of rated output voltage.	
4.Iout programming resolution	---	0.002% of rated output current.	
5.Vout readback accuracy	---	0.1% of rated output voltage.	
6.Iout readback accuracy (*13)	---	0.2% of rated output current.	
7.Vout readback resolution	% of rated output voltage	0.008%	0.008%
8.Iout readback resolution	% of rated output current	0.002%	0.002%

**PROTECTIVE FUNCTIONS**

	V	1000	1500
1.Foldback protection	---	Output shut-down when power supply changes mode from CV or Power Limit to CC mode or from CC or Power Limit to CV mode. User presetable. Reset by AC input recycle in autostart mode, by Power Switch, by OUTPUT button, by rear panel or by communication.	
2.Over-voltage protection (OVP)	---	Output shut-down. Reset by AC input recycle in autostart mode, by Power Switch, by OUTPUT button, by rear panel or by communication.	
3.Over-voltage programming range	V	5~1102.5	5~1653.75
4.Over-voltage programming accuracy	---	+/-1% of rated output voltage.	
5.Output under voltage limit (UVL)	---	Prevents from adjusting Vout below limit. Does not apply in analog programming. Preset by front panel or communication port.	
6.Over temperature protection	---	Shuts down the output. Auto recovery by autostart mode.	
7.Output under voltage protection (UVP)	---	Prevents adjustment of Vout below limit. P.S output turns Off during under voltage condition. Reset by AC input recycle in autostart mode, by Power Switch, by OUTPUT button, by rear panel or by communication.	

**FRONT PANEL**

1.Control functions	---	Multiple options with 2 Encoders.
	---	Vout/Iout/Power Limit manual adjust.
	---	OVP/UVL/UVP manual adjust.
	---	Protection Functions - OVP, UVL, UVP, Foldback, OCL, ENA, ILC.
	---	Communication Functions - Selection of LAN, RS232, RS485, USB or Optional communication interface.
	---	Output ON/OFF. Front Panel Lock.
	---	Communication Functions - Selection of Baud Rate, Address, IP and communication language.
	---	Analog Control Functions - Selection Voltage/resistive programming 5V/10V, 5KΩ/10KΩ programming.
2.Display	---	Analog Monitor Functions - Selection of Voltage/Current Monitoring 5V/10V.
	---	Vout: 4 digits, accuracy: 0.05% of rated output voltage +/-1 count. Iout: 4 digits, accuracy: 0.2% of rated output current +/-1 count.
3.Front Panel Buttons Indications	---	OUTPUT ON, ALARM, PREVIEW, FINE, COMMUNICATION, PROTECTION, CONFIGURATION, SYSTEM, SEQUENCER.
4.Front Panel Display Indications	---	Voltage, Current, Power, CV, CC, CP, External Voltage, External Current, Address, LFP Autostart, Safetstart, Foldback V/I, Remote (communication), RS/USB/LAN/Optional communication interface, Trigger, Load/Store Cell.
5.Circuit breaker	---	The AC supply for the Power System unit is protected by 3 x 80A circuit breakers. These CB's are accessible on the front panel of the cabinet.

**ENVIRONMENTAL CONDITIONS**

1.Operating temperature	---	0~50°C, 100% load.
2.Storage temperature	---	-25~65°C.
3.Operating humidity	---	20~90% RH (no condensation).
4.Storage humidity	---	10~95% RH (no condensation).
5.Altitude(*15)	---	Operating: 10000ft (3000m), output current derating 2%/100m or Ta derating 1°C/100m above 2000m. Non-operating: 40000ft (12000m).

**MECHANICAL**

1.Cooling	---	Forced air cooling by power supply internal fans. Airflow direction: From cabinet front panel to rear.
2.Weight	Kg	Less than 180.
3.Dimensions (WxHxD)	mm	W: 553, H: 1028 (With Castors; Without castors cabinet height is 947), D: 902.
4.Vibration (Package transportation)	---	ISTA 1H: 2014, Method: ASTM D4728 Random vibration test.
5.Shock & Drop (Package transportation)	---	ISTA 1H: 2014, Drop test Method: ASTM D5276 free fall; Rotation edge drop test: ASTM D6179 Rotational drop.

**SAFETY/EMC**

1.Safety standards	---	IEC 61010-1:2010, EN 61010-1:2010
1.1.Interface classification	---	Output & J8 (sense) are hazardous, J1, J2, J3, J4, J5, J6, J7 & J9 (communication options) are Non Hazardous.
1.2.Withstand voltage	---	Input - Output & J8 (sense), J1, J2, J3, J4, J5, J6, J7 and J9 (communication options): 4000VDC 1min,
	---	Output & J8 (sense) - J1, J2, J3, J4, J5, J6, J7 & J9 (communication options): 2250VDC 1min, Output & J8 (sense) - Ground: 3280VDC 1min. Input - Ground: 2835VDC 1min.
2.EMC standards (*16) (*17)	---	IEC/EN61204-3 Industrial environment.
2.1.Conducted emission (*17)	---	IEC/EN61204-3 Industrial environment, Annex H table H.1, FCC Part 15-A, VCCI-A.
2.2.Radiated emission (*17)	---	IEC/EN61204-3 Industrial environment, Annex H table H.3 and H.4, FCC Part 15-A, VCCI-A.

REVISION:  
IA1038-01-02A

**NOTES:**

- \*1: Minimum voltage is guaranteed to maximum 0.1% of rated output voltage.
- \*2: Minimum current is guaranteed to maximum 0.2% of rated output current.
- \*3: Typ. at Ta=25°C, rated output power.
- \*4: For cases where conformance to various safety standards (UL, IEC, etc...) is required, to be described as 380~480Vac (50/60Hz) for 3-Phase 480V models.
- \*5: 3-Phase 480V: At 380Vac input voltage. With rated output power.
- \*6: 3-Phase 480V models: 342~528Vac. Constant load.
- \*7: From No-Load to Full-Load, constant input voltage. Measured at the sensing point in Remote Sense.
- \*8: The maximum voltage on the power supply terminals must not exceed the rated voltage.
- \*9: From 10% to 90% of Rated Output Voltage at rated resistive load.
- \*10: From 90% to 10% of Rated Output Voltage.
- \*11: For load voltage change, equal to the unit voltage rating, constant input voltage.
- \*12: For steady state only.
- \*13: The Constant Current programming, readback and monitoring accuracy do not include the warm-up and Load regulation thermal drift.
- \*14: Measured at the sensing point.
- \*15: Max. ambient temperature for IEEE is 40°C.
- \*16: Signal and control ports interface cables length: Less than 3m, DC output power port cables length: Less than 30m.
- \*17: EMC specs based on GSPL22.5kW series.

## 5.6 90kW Series Specifications

Unless otherwise noted, specifications are warranted over the ambient temperature range of 0° to 50° Celsius.

OUTPUT RATING		20-4500	30-3000	40-2256	60-1500	80-1128	100-900	150-600	200-450	300-300	400-225	600-150	1000-90	1500-60
1. Rated output voltage (*1)	V	20	30	40	60	80	100	150	200	300	400	600	1000	1500
2. Rated output current (*2)	A	4500	3000	2256	1500	1128	900	600	450	300	225	150	90	60
3. Rated output power	W	90000	90000	90240	90000	90240	90000	90000	90000	90000	90000	90000	90000	90000

INPUT CHARACTERISTICS		V	20	30	40	60	80	100	150	200	300	400	600	1000	1500
1. Input voltage/freq. 3 phase, 3 wire+ground (*4)	---	3-Phase, 480V models: 342~528Vac, 47~63Hz (Covers 380/400/415/440/460/480Vac).													
2. Maximum Input current at 100% load 480V models:	3-Phase, ---	162A @ 380Vac.													
3. Power Factor (Typ.)	---	0.94 @ 380Vac, rated output power.													
4. Efficiency (Minimum) (*3) (*5)	%	89	89	89	90										

CONSTANT VOLTAGE MODE		V	20	30	40	60	80	100	150	200	300	400	600	1000	1500
1. Max. Line regulation (*6)	---	0.01% of rated output voltage.													
2. Max. Load regulation (*7)	---	0.01% of rated output voltage +5mV.													
3. Temperature coefficient	---	50PPM/°C from rated output voltage, following 30 minutes warm-up.													
4. Temperature stability	---	0.01% of rated Vout over 8hrs. interval following 30 minutes warm-up. Constant line, load & temperature.													
5. Warm-up drift	---	Less than 0.05% of rated output voltage +2mV over 30 minutes following power on.													
6. Remote sense compensation/wire (*8)	V	2	5												
7. Up-prog. response time (*9)	mS	30	30	30	50	50	50	50	50	50	50	60	100	150	200
8. Down-prog. response time	Full load (*10)	50	80	80	80	100	100	100	100	100	100	100	100	100	100
	No load (*10)	600	600	1000	1000	1000	1500	2500	2500	3000	3000	3000	3000	3000	3000
9. Transient response time	---	Time for output voltage to recover within 1% of its rated output for 20~30V; 0.5% of its rated output for 40~1500V, for a load change 10~90% of rated output current Local sense. Output set point: 10~100%. Less than 1mS for models up to and including 100V. 2mS for models above 100V.													

CONSTANT CURRENT MODE		V	20	30	40	60	80	100	150	200	300	400	600	1000	1500
1. Max. Line regulation (*6)	---	0.05% of rated output current.													
2. Max. Load regulation (*11)	---	0.08% of rated output current.													
3. Temperature coefficient	---	20~100V models: 100PPM/°C from rated output current, following 30 minutes warm-up. 150~1500V models: 70PPM/°C from rated output current, following 30 minutes warm-up.													
4. Temperature stability	---	0.01% of rated Iout over 8hrs. interval following 30 minutes warm-up. Constant line, load & temperature.													
5. Warm-up drift	---	20~100V models: Less than +/-0.25% of rated output current over 30 minutes following power on. 150~1500V models: Less than +/-0.15% of rated output current over 30 minutes following power on.													

### ANALOG PROGRAMMING AND MONITORING (ISOLATED FROM THE OUTPUT)

1. Vout voltage programming	---	0~100%, 0~5V or 0~10V, user selectable. Accuracy and linearity: +/-0.15% of rated Vout.													
2. Iout voltage programming (*13)	---	0~100%, 0~5V or 0~10V, user selectable. Accuracy and linearity: +/-0.4% of rated Iout.													
3. Vout resistor programming	---	0~100%, 0~5/10KΩ full scale, user selectable. Accuracy and linearity: +/-0.5% of rated Vout.													
4. Iout resistor programming (*13)	---	0~100%, 0~5/10KΩ full scale, user selectable. Accuracy and linearity: +/-0.5% of rated Iout.													
5. Output voltage monitor (*12)	---	0~5V or 0~10V, user selectable. Accuracy: +/-0.5% of rated Vout.													
6. Output current monitor (*12) (*13)	---	0~5V or 0~10V, user selectable. Accuracy: +/-0.5% of rated Iout.													

### SIGNALS AND CONTROLS (ISOLATED FROM THE OUTPUT)

1. Power supply OK #1 signal	---	Power supply output monitor. Open collector. Output On: On. Output Off: Off. Maximum Voltage: 30V. Maximum Sink Current: 10mA.													
2. CV/CC signal	---	CV/CC Monitor. Open collector. CC mode: On. CV mode: Off. Maximum Voltage: 30V. Maximum Sink Current: 10mA.													
3. LOCAL/REMOTE Analog control	---	Enable/Disable analog programming control by electrical signal or dry contact. Remote: 0~0.6V or short. Local: 2~30V or open.													
4. LOCAL/REMOTE Analog signal	---	Analog programming control monitor signal. Open collector. Remote: On. Local: Off. Maximum Voltage: 30V. Maximum Sink Current: 10mA.													
5. ENABLE/DISABLE signal	---	Enable/Disable PS output by electrical signal or dry contact. 0~0.6V or short, 2~30V or open. User selectable logic.													
6. INTERLOCK (ILC) control	---	Enable/Disable PS output by electrical signal or dry contact. Output ON: 0~0.6V or short. Output OFF: 2~30V or open.													
7. Programmed signals	---	Two open drain programmable signals. Maximum voltage 25V. Maximum sink current 100mA (shunted by 27V zener).													
8. TRIGGER IN / TRIGGER OUT signals	---	Maximum low level input voltage = 0.8V. Minimum high level input voltage = 2.5V. Maximum high level input = 5V positive edge trigger: tw = 10uS minimum. Tr, Tf = 1uS maximum. Min delay between 2 pulses 1mS.													
9. DAISY_IN/SO control signal	---	By electrical Voltage: 0~0.6V/2~30V or dry contact.													
10. DAISY_OUT/PS_OK #2 signal	---	4~5V = OK, 0V (500Ω impedance) = Fail.													

## FUNCTIONS AND FEATURES

1.Parallel operation	---	Consult with manufacturer.
2.Constant power control	---	Limits the output power to a programmed value. Programming via the communication ports or the front panel.
3.Output resistance control	---	Emulates series resistance. Resistance range: 1~1000mΩ. Programming via communication ports or front panel.
4.Slew rate control	---	Programmable Output rise and Output fall slew rate. Programming range: 0.0001~999.99 V/mS. or A/mS. Programming via communication ports or front panel.
5.Arbitrary waveforms	---	Profiles of up to 100 steps can be stored in 4 memory cells. Activation by command via communication ports or front panel.

## PROGRAMMING AND READBACK (USB, LAN, RS232/485, Optional (\*15) (\*16) Interfaces)

	V	20	30	40	60	80	100	150	200	300	400	600	1000	1500	
1.Vout programming accuracy (*14)	---	0.05% of rated output voltage.													
2.Iout programming accuracy (*13)	---	0.3% of rated output current.													
3.Vout programming resolution	---	0.002% of rated output voltage.													
4.Iout programming resolution	---	0.002% of rated output current.													
5.Vout readback accuracy	---	0.1% of rated output voltage.													
6.Iout readback accuracy (*13)	---	0.2% of rated output current.													
7.Vout readback resolution	% of rated output voltage	0.006%	0.004%	0.004%	0.003%	0.002%	0.011%	0.008%	0.006%	0.004%	0.003%	0.003%	0.011%	0.008%	
8.Iout readback resolution	% of rated output current	0.002%	0.002%	0.002%	0.002%	0.002%	0.002%	0.002%	0.003%	0.002%	0.002%	0.002%	0.002%	0.002%	

## PROTECTIVE FUNCTIONS

	V	20	30	40	60	80	100	150	200	300	400	600	1000	1500	
1.Foldback protection	---	Output shut-down when power supply changes mode from CV or Power Limit to CC mode or from CC or Power Limit to CV mode. User presetable. Reset by AC input recycle in autostart mode, by Power Switch, by OUTPUT button, by rear panel or by communication.													
2.Over-voltage protection (OVP)	---	Output shut-down. Reset by AC input recycle in autostart mode, by Power Switch, by OUTPUT button, by rear panel or by communication.													
3.Over-voltage programming range	V	1~24	2~36	2~44.1	5~66.15	5~88.2	5~110.25	5~165.37	5~220.5	5~330.75	5~441	5~661.5	5~1102.5	5~1653.75	
4.Over-voltage programming accuracy	---	+/-1% of rated output voltage.													
5.Output under voltage limit (UVL)	---	Prevents from adjusting Vout below limit. Does not apply in analog programming. Preset by front panel or communication port.													
6.Over temperature protection	---	Shuts down the output. Auto recovery by autostart mode.													
7.Output under voltage protection (UVP)	---	Prevents adjustment of Vout below limit. P.S output turns Off during under voltage condition. Reset by AC input recycle in autostart mode, by Power Switch, by OUTPUT button, by rear panel or by communication.													

## FRONT PANEL

1.Control functions	---	Multiple options with 2 Encoders.
	---	Vout/Iout/Power Limit manual adjust.
	---	OVP/UVL/UVP manual adjust.
	---	Protection Functions - OVP, UVL, UVP, Foldback, OCL, ENA, ILC.
	---	Communication Functions - Selection of LAN, RS232, RS485, USB or Optional communication interface.
	---	Output ON/OFF. Front Panel Lock.
	---	Communication Functions - Selection of Baud Rate, Address, IP and communication language.
	---	Analog Control Functions - Selection Voltage/resistive programming 5V/10V, 5KΩ/10KΩ programming.
	---	Analog Monitor Functions - Selection of Voltage/Current Monitoring 5V/10V.
2.Display	---	Vout: 4 digits, accuracy: 0.05% of rated output voltage +/-1 count.
	---	Iout: 4 digits, accuracy: 0.2% of rated output current +/-1 count.
3.Front Panel Buttons Indications	---	OUTPUT ON, ALARM, PREVIEW, FINE, COMMUNICATION, PROTECTION, CONFIGURATION, SYSTEM, SEQUENCER.
4.Front Panel Display Indications	---	Voltage, Current, Power, CV, CC, CP, External Voltage, External Current, Address, LFP Autostart, Safetstart, Foldback V/I, Remote (communication), RS/USB/LAN/Optional communication interface, Trigger, Load/Store Cell.
5.Circuit breaker	---	The AC supply for the Power System unit is protected by 4 x 80A circuit breakers. These CB's are accessible on the front panel of the cabinet.

## ENVIRONMENTAL CONDITIONS

1.Operating temperature	---	0~50°C, 100% load.
2.Storage temperature	---	-25~65°C.
3.Operating humidity	---	20~90% RH (no condensation).
4.Storage humidity	---	10~95% RH (no condensation).
5.Altitude(*15)	---	Operating: 10000ft (3000m), output current derating 2%/100m or Ta derating 1°C/100m above 2000m. Non-operating: 40000ft (12000m).

## MECHANICAL

1.Cooling	---	Forced air cooling by power supply internal fans. Airflow direction: From cabinet front panel to rear.
2.Weight	Kg	Less than 200.
3.Dimensions (WxHxD)	mm	W: 553, H: 1028 (With Castors; Without castors cabinet height is 947), D: 902.
4.Vibration (Package transportation)	---	ISTA 1H: 2014, Method: ASTM D4728 Random vibration test.
5.Shock & Drop (Package transportation)	---	ISTA 1H: 2014, Drop test Method: ASTM D5276 free fall; Rotation edge drop test: ASTM D6179 Rotational drop.

**SAFETY/EMC**

1.Safety standards	---	IEC 61010-1:2010, EN 61010-1:2010
1.1.Interface classification	---	Vout≤50V Models: Output, J1, J2, J3, J4, J5, J6, J7, J8 (sense) & J9 (communication options) are Non Hazardous. 60≤Vout≤1500V Models: Output & J8 (sense) are hazardous, J1, J2, J3, J4, J5, J6, J7 & J9 (communication options) are Non Hazardous.
1.2.Withstand voltage	---	Vout≤50V Models: Input – Output & J8 (sense), J1, J2, J3, J4, J5, J6, J7 & J9 (communication options): 4242VDC 1min, Input - Ground: 2835VDC 1min. 60V≤Vout≤100V Models: Input – Output & J8 (sense), J1, J2, J3, J4, J5, J6, J7 & J9 (communication options): 4242VDC 1min, Output & J8 (sense) - J1, J2, J3, J4, J5, J6, J7 & J9 (communication options): 850VDC 1min, Output & J8 (sense) - Ground: 1500VDC 1min, Input - Ground: 2835VDC 1min. 100V<Vout≤600V Models: Input – Output & J8 (sense), J1, J2, J3, J4, J5, J6, J7 and J9 (communication options): 4242VDC 1min, Output & J8 (sense) - J1, J2, J3, J4, J5, J6, J7 & J9 (communication options): 1275VDC 1min, Output & J8 (sense) - Ground: 2500VDC 1min, Input - Ground: 2835VDC 1min. 1000V<Vout≤1500V Models: Input – Output & J8 (sense), J1, J2, J3, J4, J5, J6, J7 and J9 (communication options): 4000VDC 1min, Output & J8 (sense) - J1, J2, J3, J4, J5, J6, J7 & J9 (communication options): 2250VDC 1min, Output & J8 (sense) - Ground: 3280VDC 1min, Input - Ground: 2835VDC 1min.
2.EMC standards (*16) (*17)	---	IEC/EN61204-3 Industrial environment.
2.1.Conducted emission (*17)	---	IEC/EN61204-3 Industrial environment, Annex H table H.1, FCC Part 15-A, VCCI-A.
2.2.Radiated emission (*17)	---	IEC/EN61204-3 Industrial environment, Annex H table H.3 and H.4, FCC Part 15-A, VCCI-A.

**REVISION:**

IA1038-01-01B

**NOTES:**

- \*1: Minimum voltage is guaranteed to maximum 0.15% of rated output voltage for 20V and 30V models; 0.1% of rated output voltage for 40~1500V models.
- \*2: Minimum current is guaranteed to maximum 0.2% of rated output current.
- \*3: Typ. at Ta=25°C, rated output power.
- \*4: For cases where conformance to various safety standards (UL, IEC, etc...) is required, to be described as 380~480Vac (50/60Hz) for 3-Phase 480V models.
- \*5: 3-Phase 480V: At 380Vac input voltage. With rated output power.
- \*6: 3-Phase 480V models: 342~528Vac. Constant load.
- \*7: From No-Load to Full-Load, constant input voltage. Measured at the sensing point in Remote Sense.
- \*8: The maximum voltage on the power supply terminals must not exceed the rated voltage.
- \*9: From 10% to 90% of Rated Output Voltage at rated resistive load.
- \*10: From 90% to 10% of Rated Output Voltage.
- \*11: For load voltage change, equal to the unit voltage rating, constant input voltage.
- \*12: For steady state only.
- \*13: The Constant Current programming, readback and monitoring accuracy do not include the warm-up and Load regulation thermal drift.
- \*14: Measured at the sensing point.
- \*15: Max. ambient temperature for IEEE is 40°C.
- \*16: Signal and control ports interface cables length: Less than 3m, DC output power port cables length: Less than 30m.
- \*17: EMC specs based on GSPL22.5kW series.